

**THAR**  
**R O X X**

---

**'THE' SUV**

# OPPORTUNITY MAPPING



## Recap

**SUV Industry Volume Distribution across Price Segments**

**Ex Showroom Price (lacs)**

**SUV Industry Volume %**

**SUV Industry Revenue %**

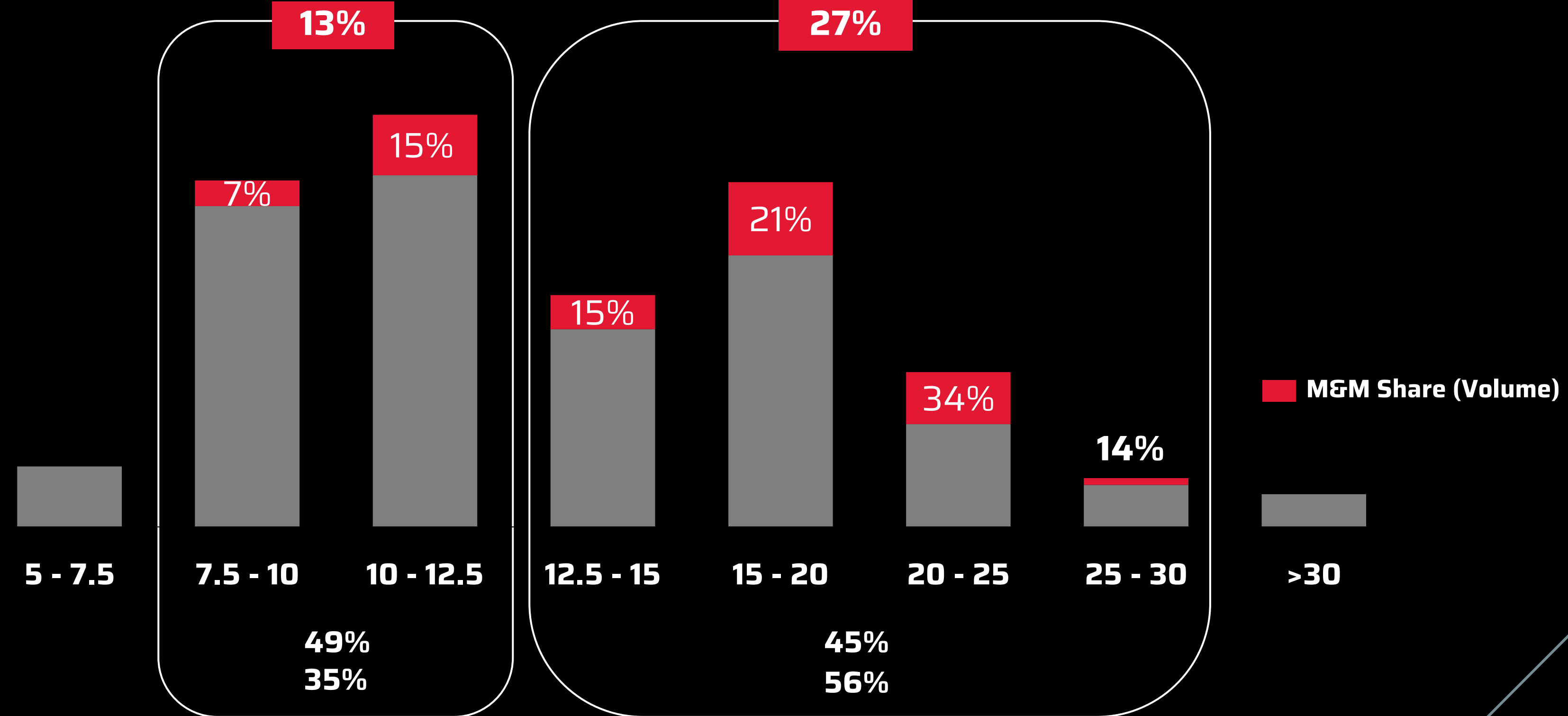

# >12.5L SUV Price Segment

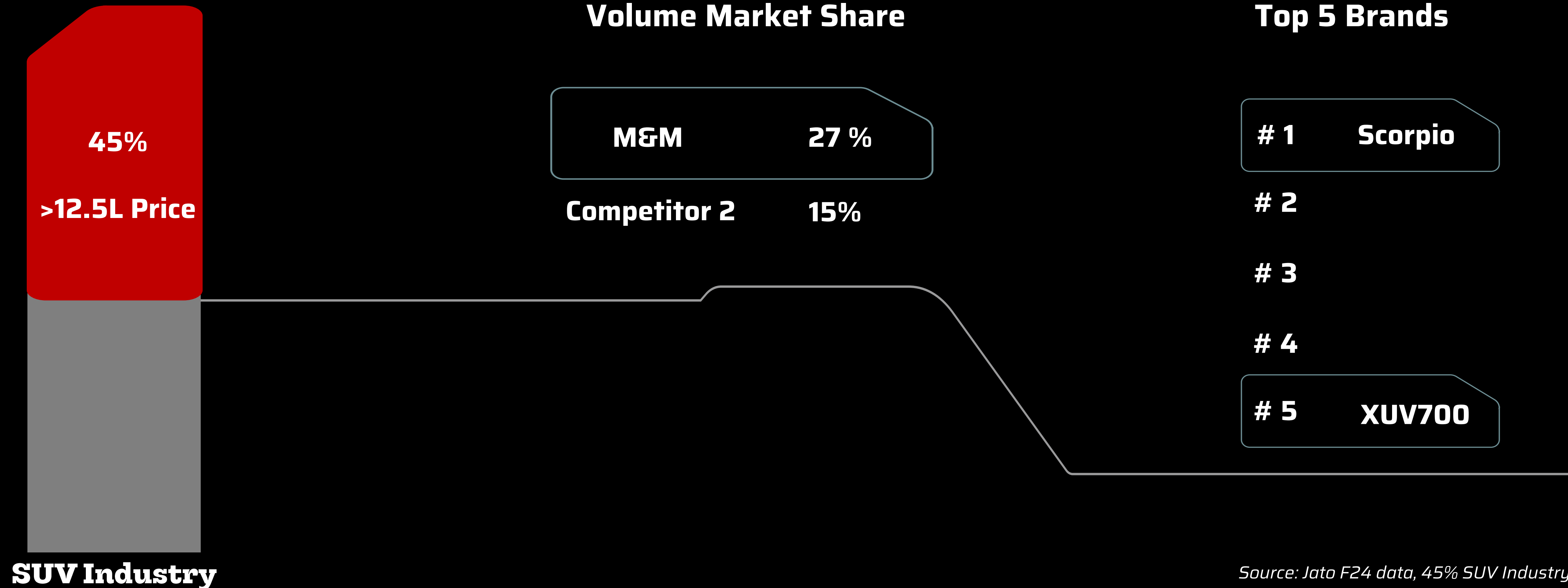

Source: Jato F24 data, 45% SUV Industry in >12.5 L to 30 L price range

# THE OPPORTUNITY FOR 'THE' SUV

**# 1** SUV Brand\*  
in >12.5L Price  
Segment  
in next 3-5 years

*\* #1 SUV Brand by Volume; >12.5 L Ex Showroom Price Segment of SUVs (defined as per Jato)*



# THAR HAS CREATED AN UNCONTESTED MARKET SEGMENT

Thar 3D - Generation 1

Thar 3D - Generation 2

Monthly Average Sales Thar vs Competition

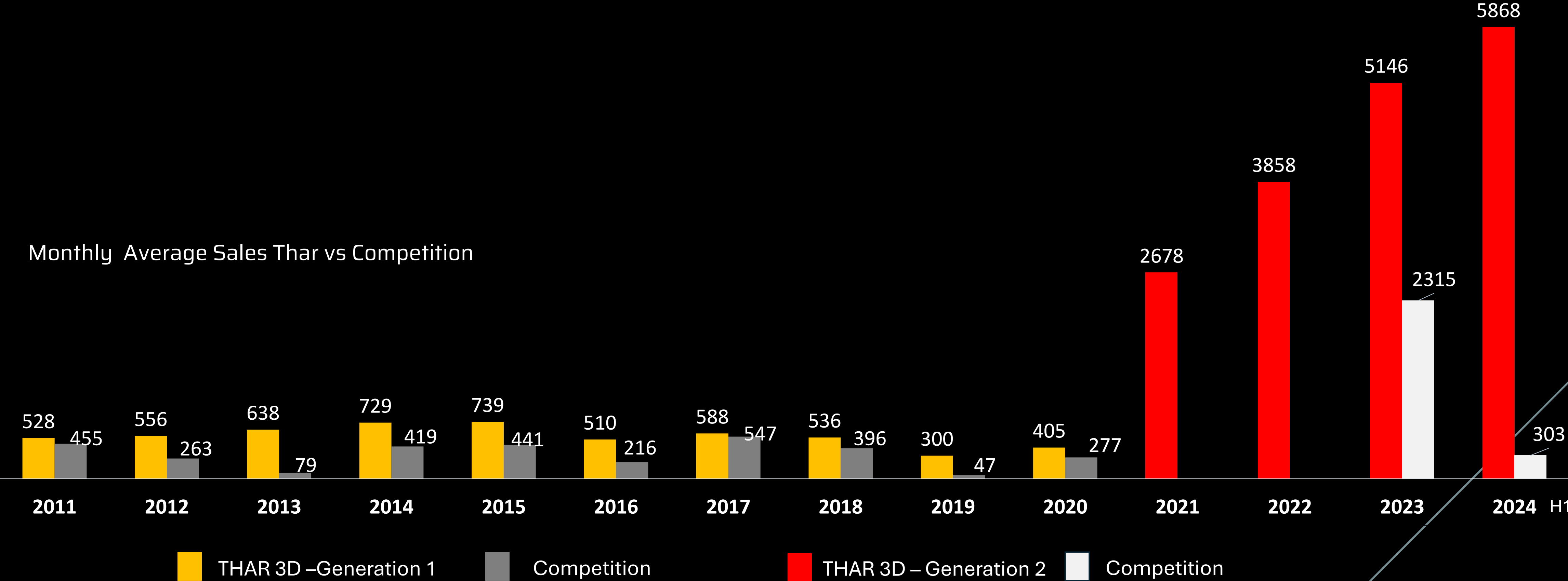

# THAR CUSTOMERS

Thar is attracting young buyers to Mahindra's fold

2/3<sup>rd</sup> Thar consumers come from smaller families (up to 5 members)

88% Consumers are additional car buyers (already own a car)

25% 4WD considerers do not consider any other vehicle

Another 30% 4WD Considerers only consider Mahindra vehicles



# 5 Reasons Why Thar ROXX is “THE” SUV





THAR  
ICONIC

IS ICONIC AND RARE, BUT WITH A HEART  
OF GOLD



BOLERO  
MONOLITHIC

IS MONOLITHIC AND SOLID, YET MAKES YOUR  
HEART MELT

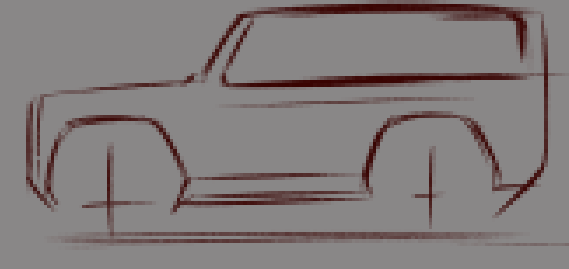

SCORPIO  
MUSCULAR

IS ALL MUSCLE,  
THAT MAKES YOUR HEART  
POUND FASTER



XUV  
ATHLETIC

MAKES YOUR HEART BEAT  
WHILST STANDING STILL,  
YET LEAVES OTHERS STANDING IN A HEART BEAT



Be.  
ELECTRIFYING

IS ELECTRIC,  
AND SHOCKINGLY BEAUTIFUL  
TO MAKE YOUR PULSE RACE

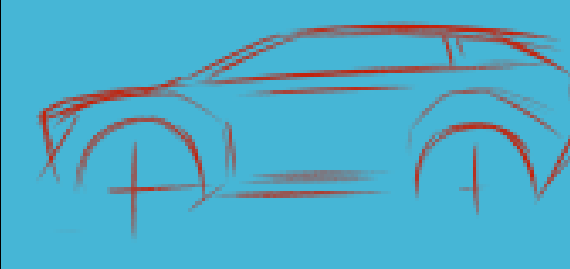

HEARTCORE  
DESIGN

mahindra  
GLOBAL DESIGN



Exterior Design

**mahindra**  
GLOBAL DESIGN

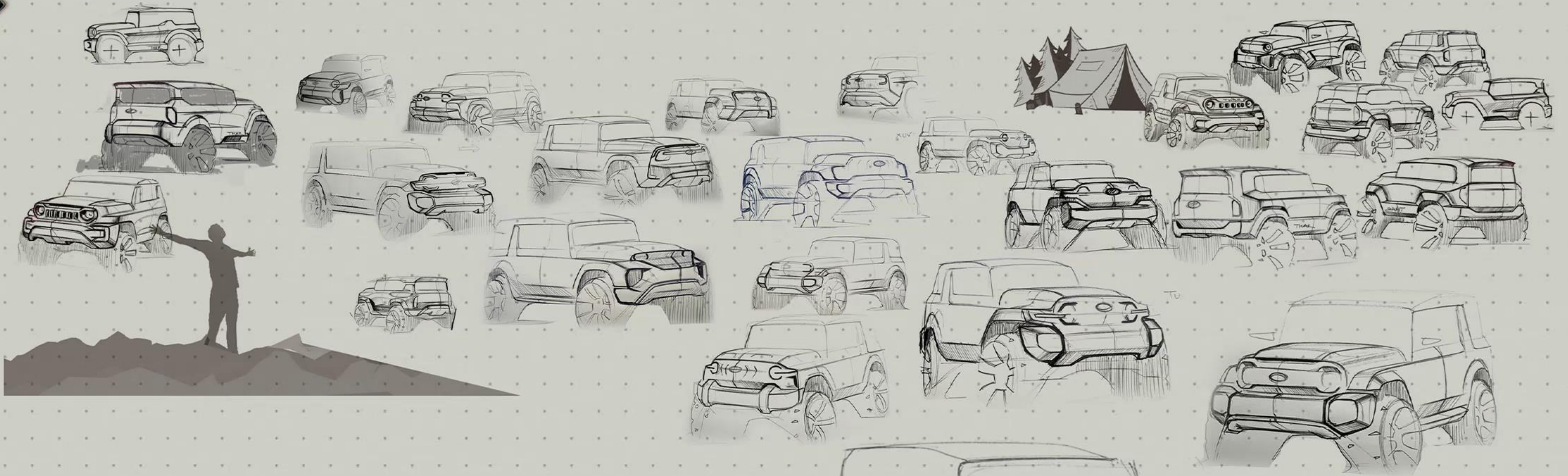

Shoulder crease pierces through the hood and continues through the lamps.  
This curve tightly holds the entire form showing solidity.

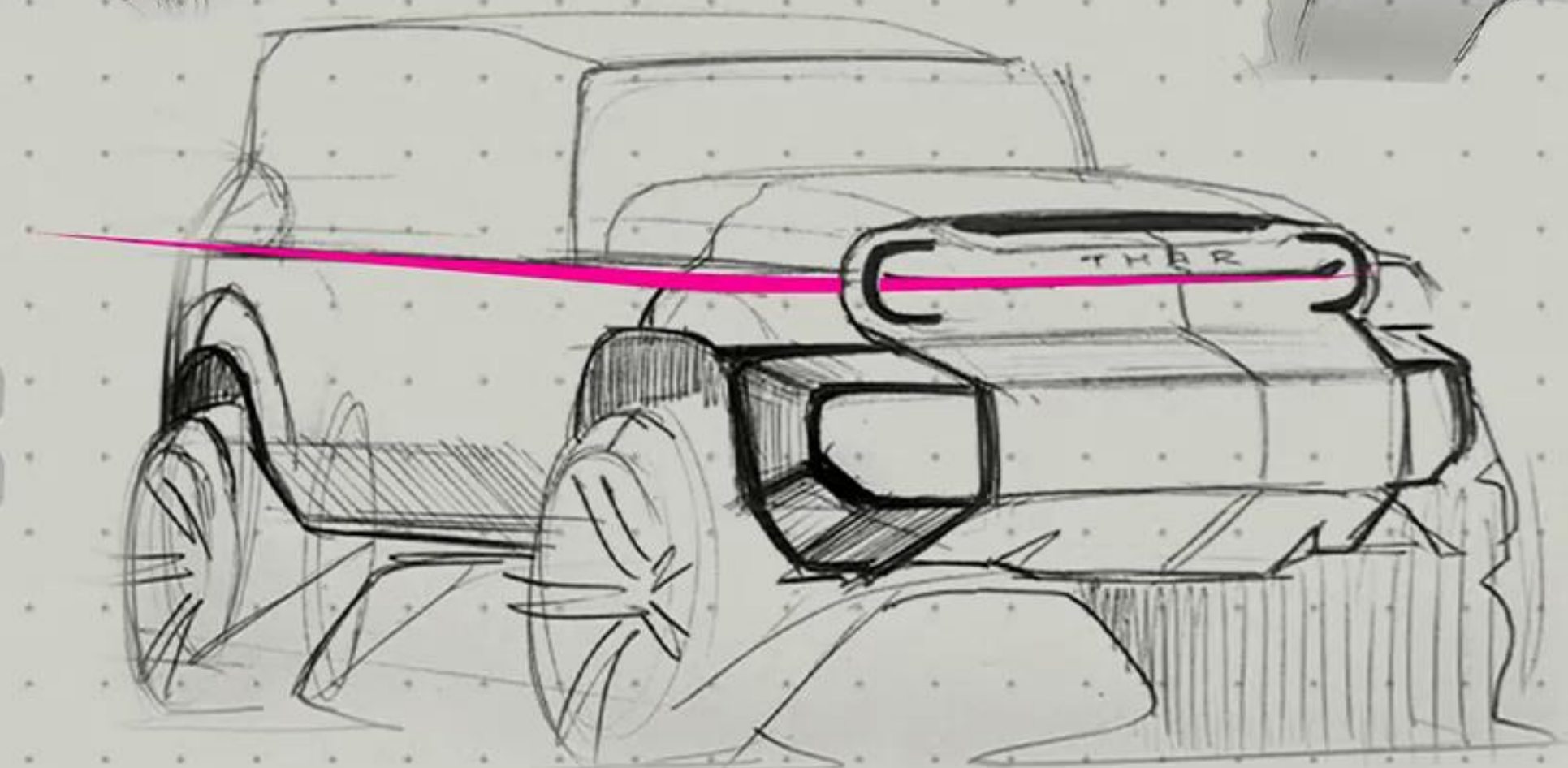

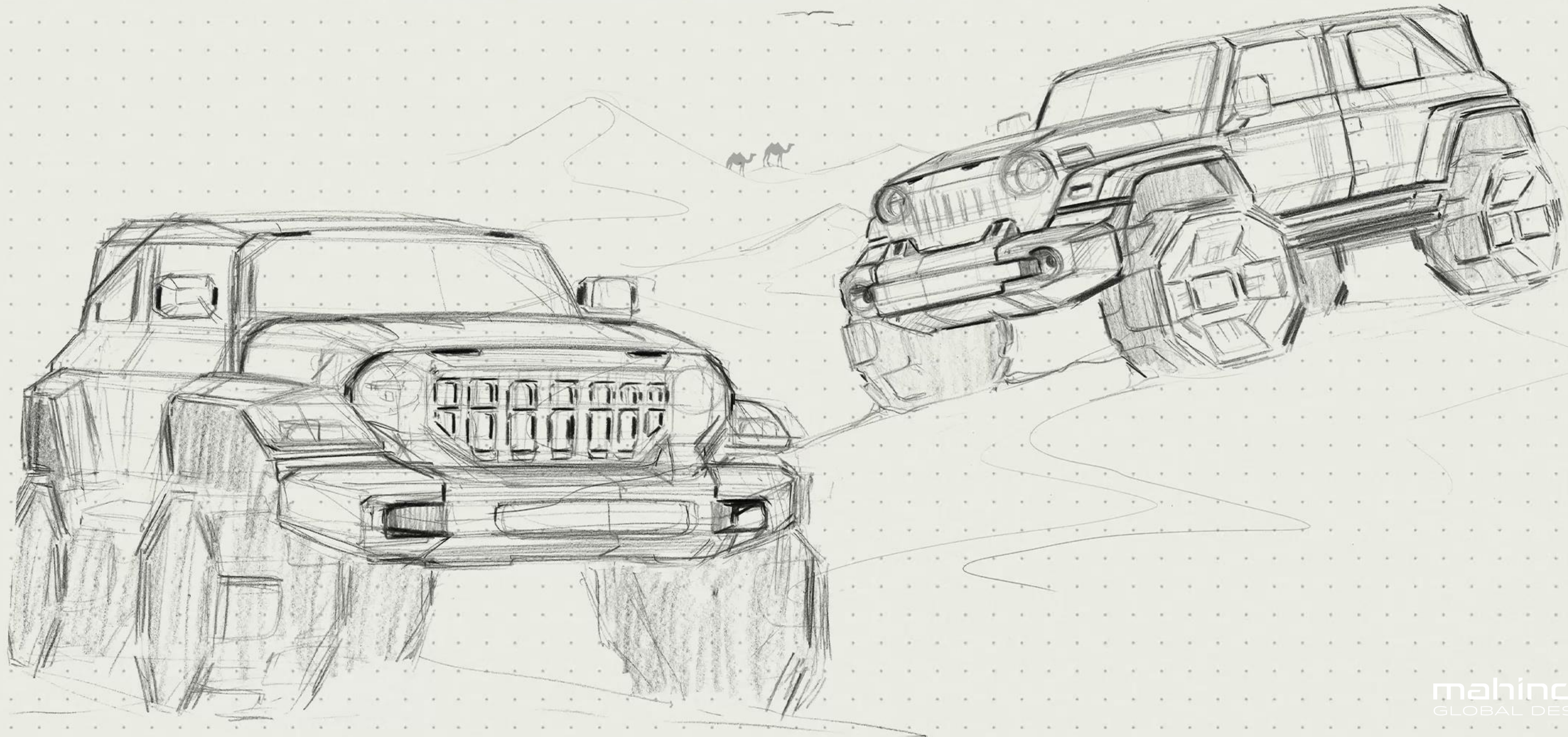



**mahindra**  
GLOBAL DESIGN



**mahindra**  
GLOBAL DESIGN



**mahindra**  
GLOBAL DESIGN







**mahindra**  
GLOBAL DESIGN



**mahindra**  
GLOBAL DESIGN



A wide-angle landscape photograph featuring a cracked, dry salt flat in the foreground. The ground is covered in a network of irregular, light-colored cracks. In the distance, a range of dark, silhouetted mountains stretches across the horizon. The sky is filled with soft, white and grey clouds, with a hint of a sunset or sunrise glow. The overall color palette is muted, dominated by blues, greys, and earthy tones.

**DON'T JUST RIDE,  
GLIDE**

# WGLYDE

It is not just a Ride, but a Glide

**60+**  
**Patents**

**Next generation Frame**  
Light-weight & High Stiffness

**Electric Power Steering**  
Premium steering feel

**Advanced damper technologies**  
MTV-CL, FDD & HRS

**Penta Link Suspension with Watt's link**  
Galileo inspired kinematics

**Enhanced 4x4**  
Legendary off-road performance

**Independent Double Wishbone Suspension**  
Archimedes inspired geometry

**Mass distribution (Front : Rear)**  
Kerb condition - 50:50    GVW condition - 45:55

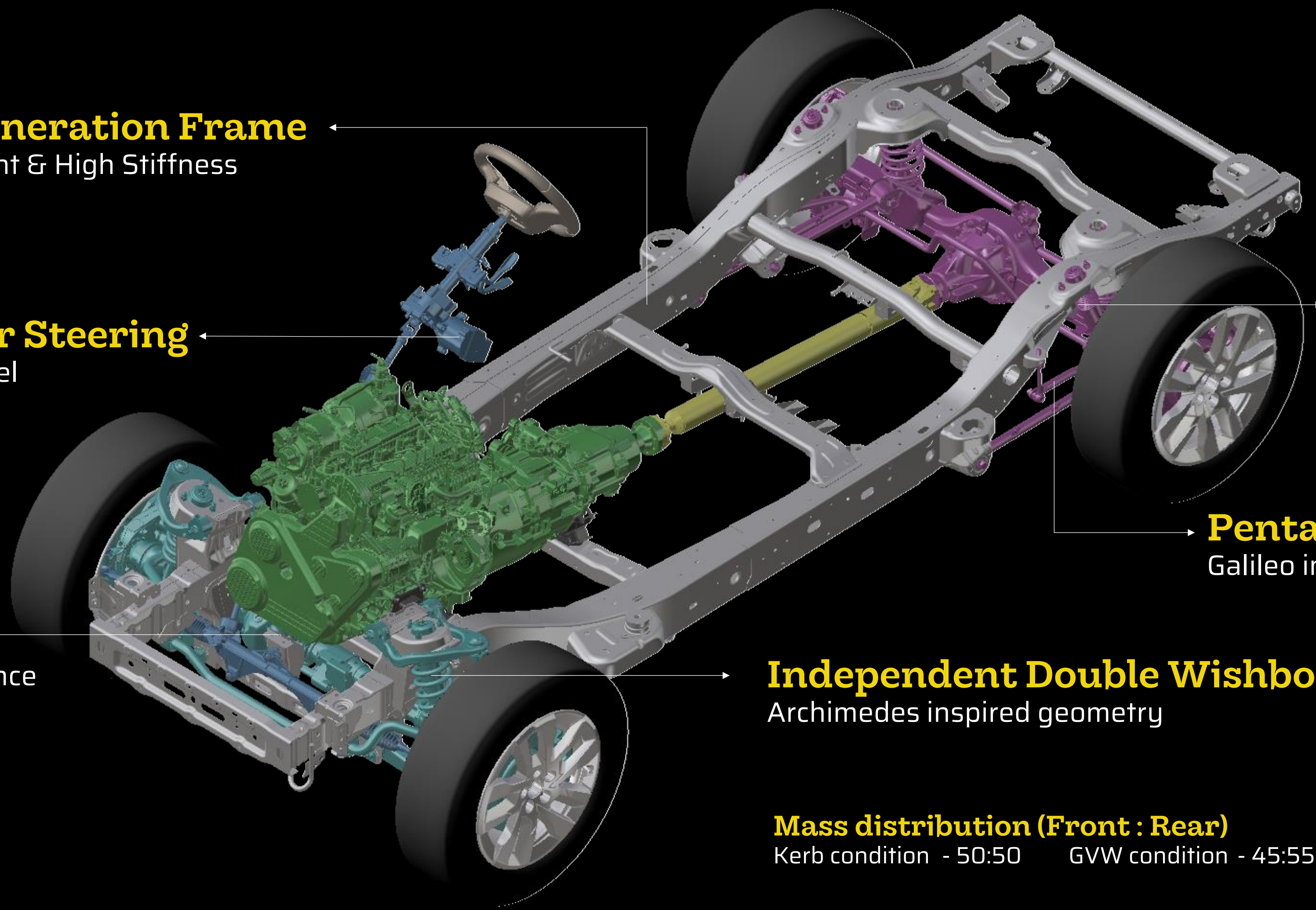

# WGLYDE : Next Gen Frame

## Light-weight, High-Stiffness & Frequency

Best in class

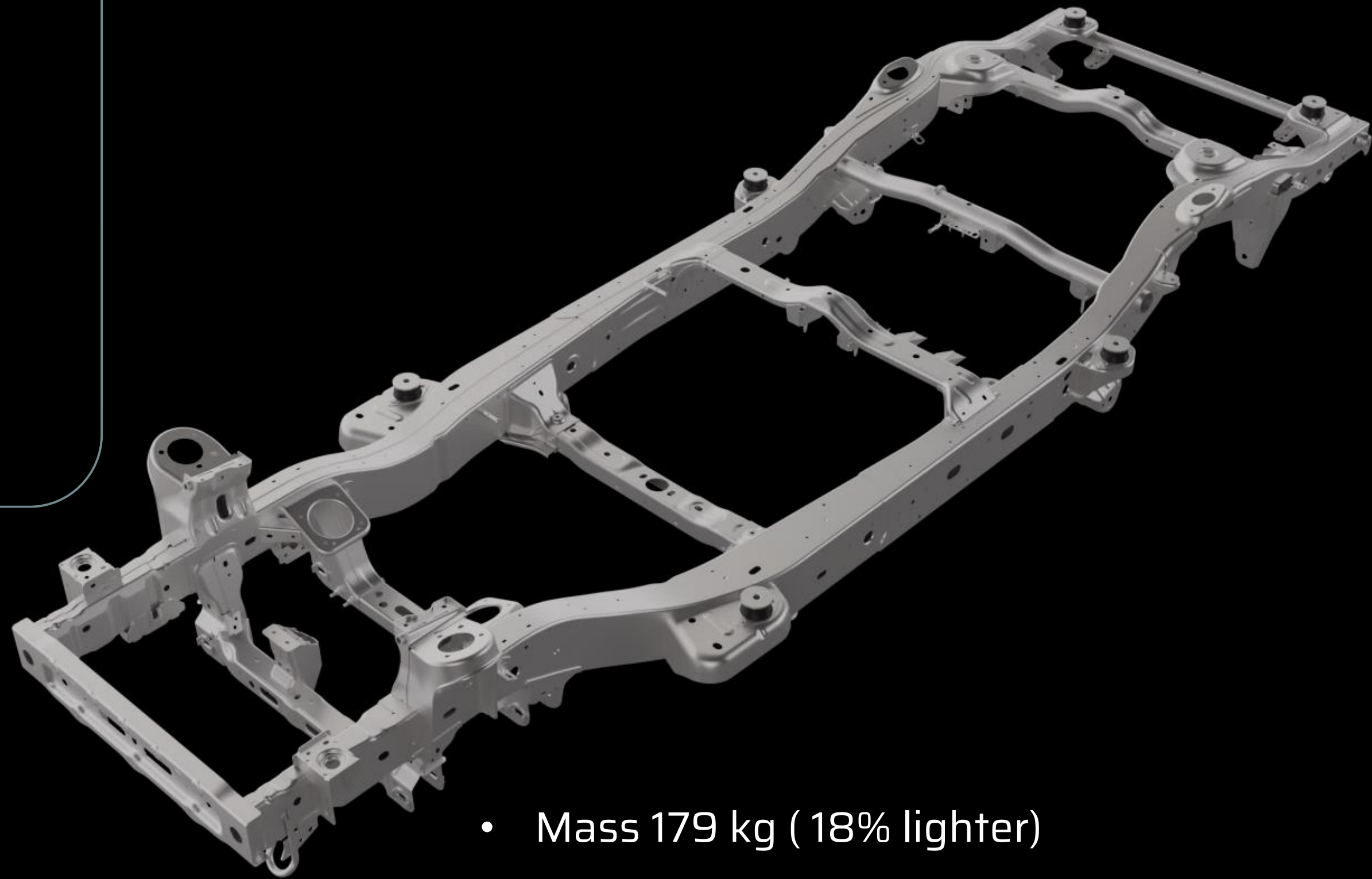

- Mass 179 kg ( 18% lighter)
- Bending Frequency - 39.9 Hz (41 % higher)
- Torsional Frequency - 34.3 Hz (51 % higher)

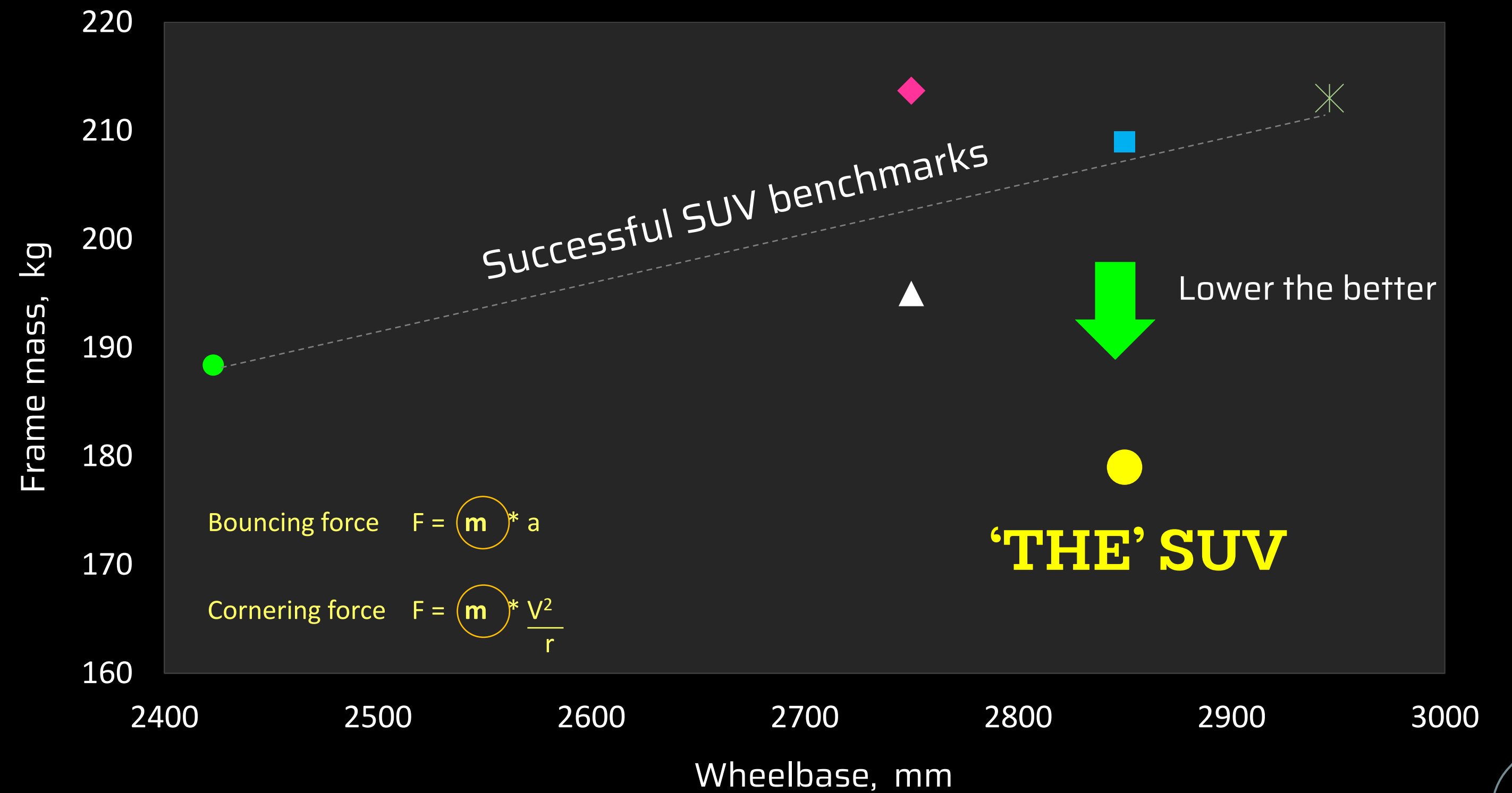

**'Mass is enemy of dynamics'**

# GLYDE : World Class Suspension

## Glide with Maximum Cornering Power

### Front : Independent Double Wishbone

Archimedes inspired geometry

*Give me a lever long enough, and I shall move the world*  
- Archimedes

### Rear : Rigid axle with Penta-link

Galileo inspired Kinematics

*Path of a projectile is a parabola*  
- Galileo

**Soft bush (90 kg/mm)**  
Ride plushness

**Tall knuckle**  
Premium steering feel,  
maximum cornering power

**Ride plushness**

**Wider damper span – 1083 mm**  
(50 % better than benchmark)

**1<sup>st</sup> in Segment**

**Watt's link**  
Superior sway control,  
High cornering confidence

**Stiff bush (1300 kg/mm)**  
Direct & Precise steering

**1<sup>st</sup> in Segment**

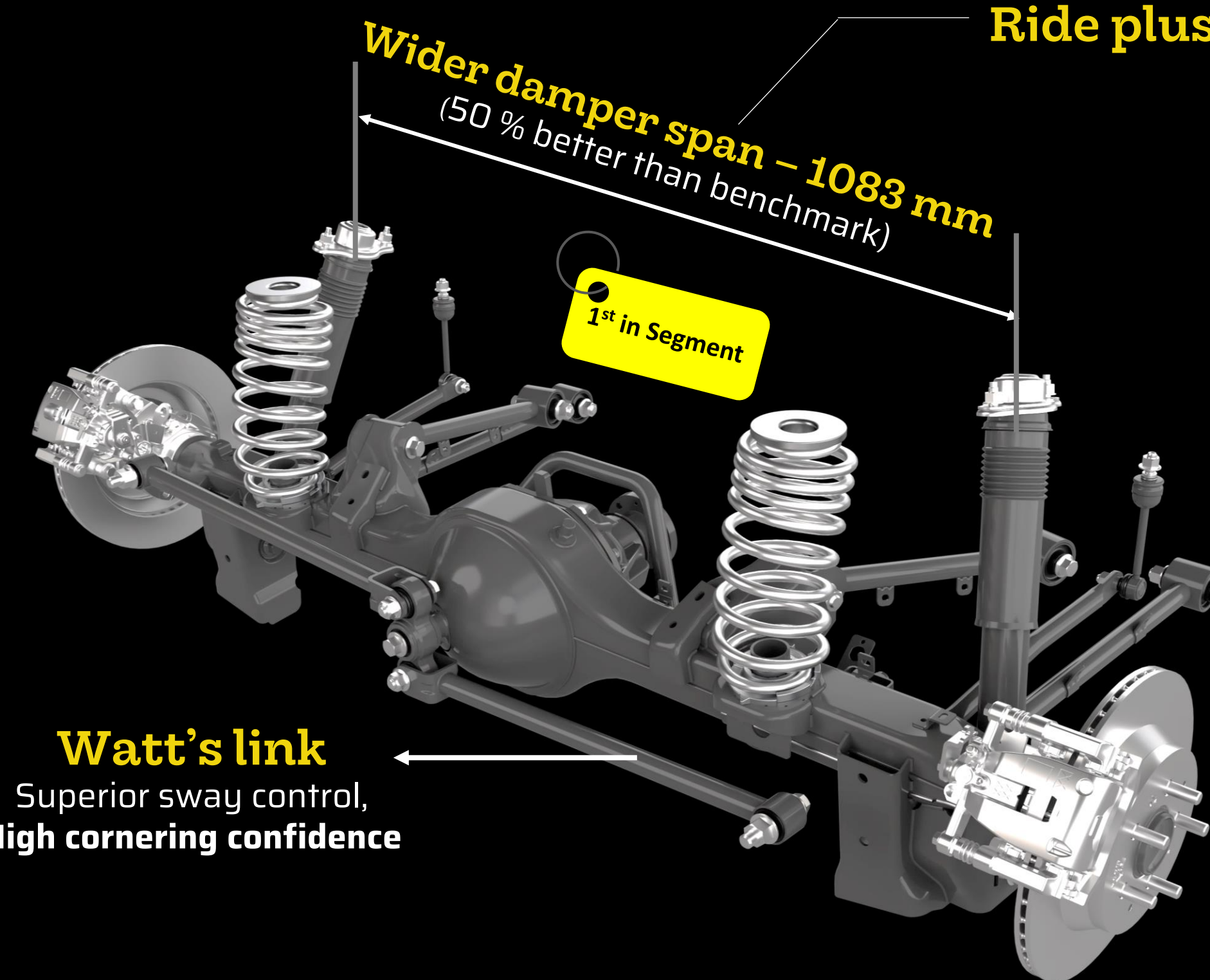
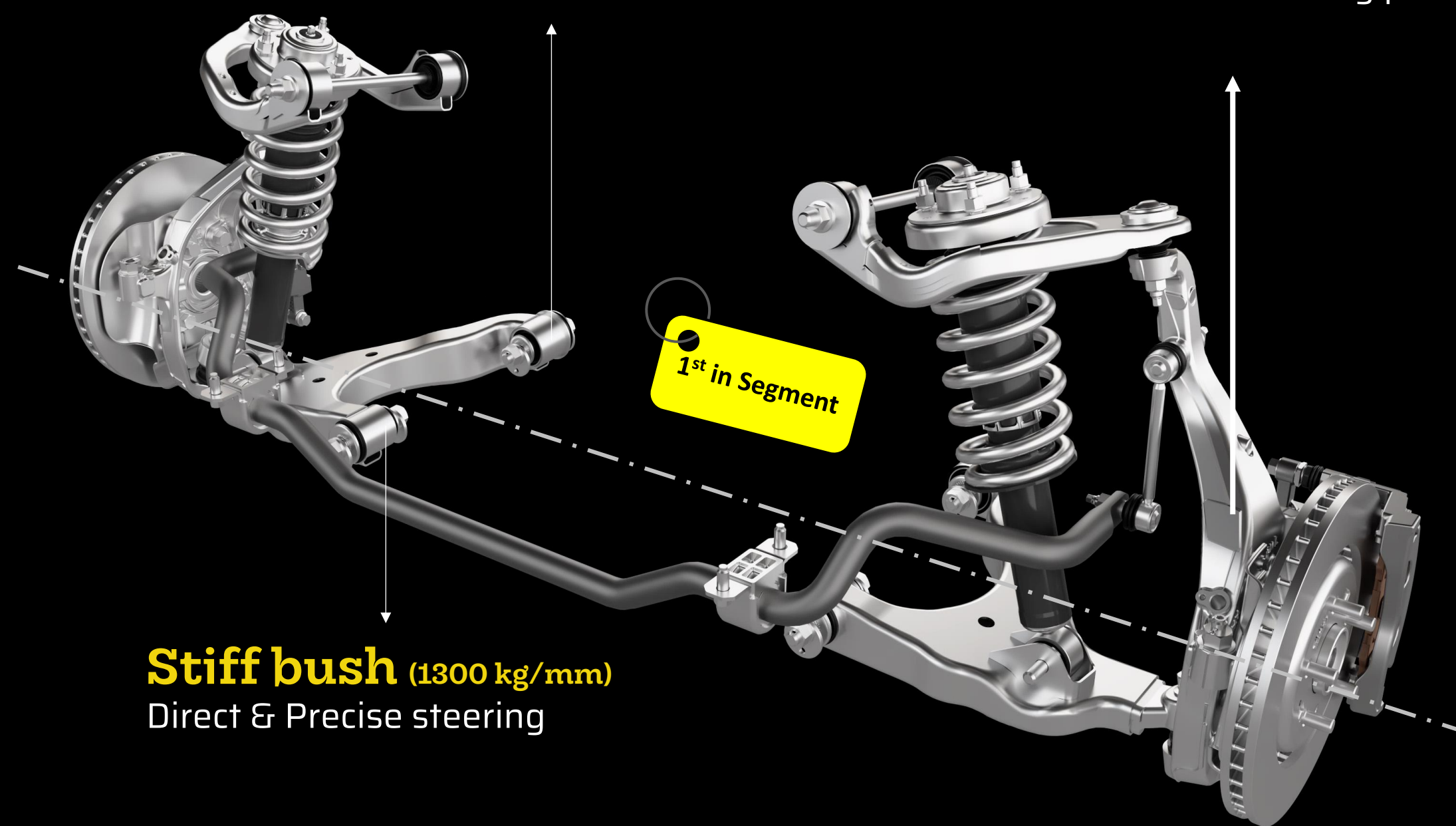

# WGLYDE : Advanced Damper Technologies

Glide in all driving conditions

## MTV-CL

(Multi-tune valve with concentric land)

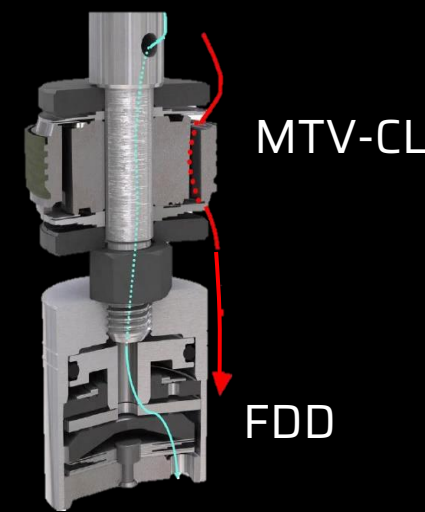
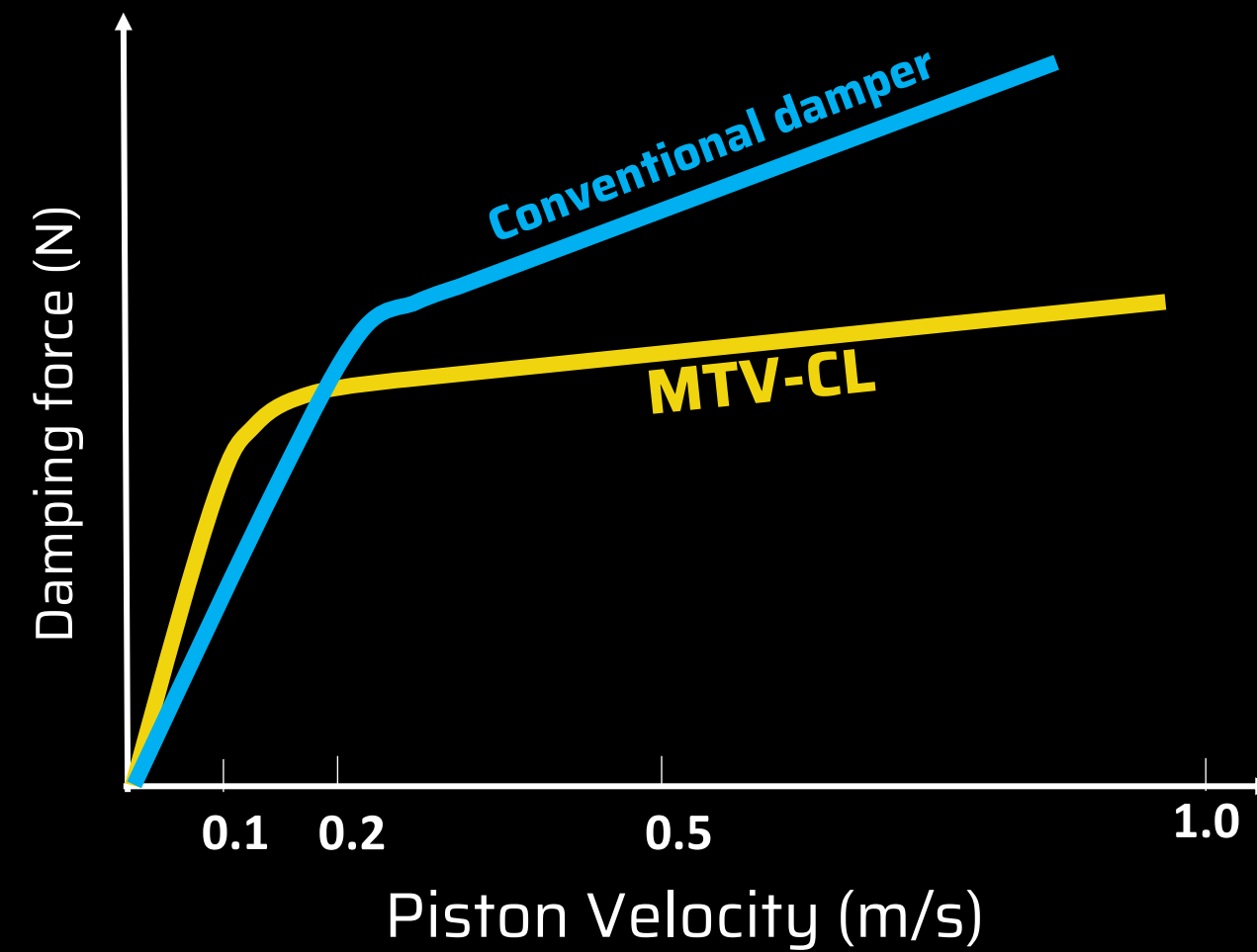

## FDD

(Frequency Dependent Damping)

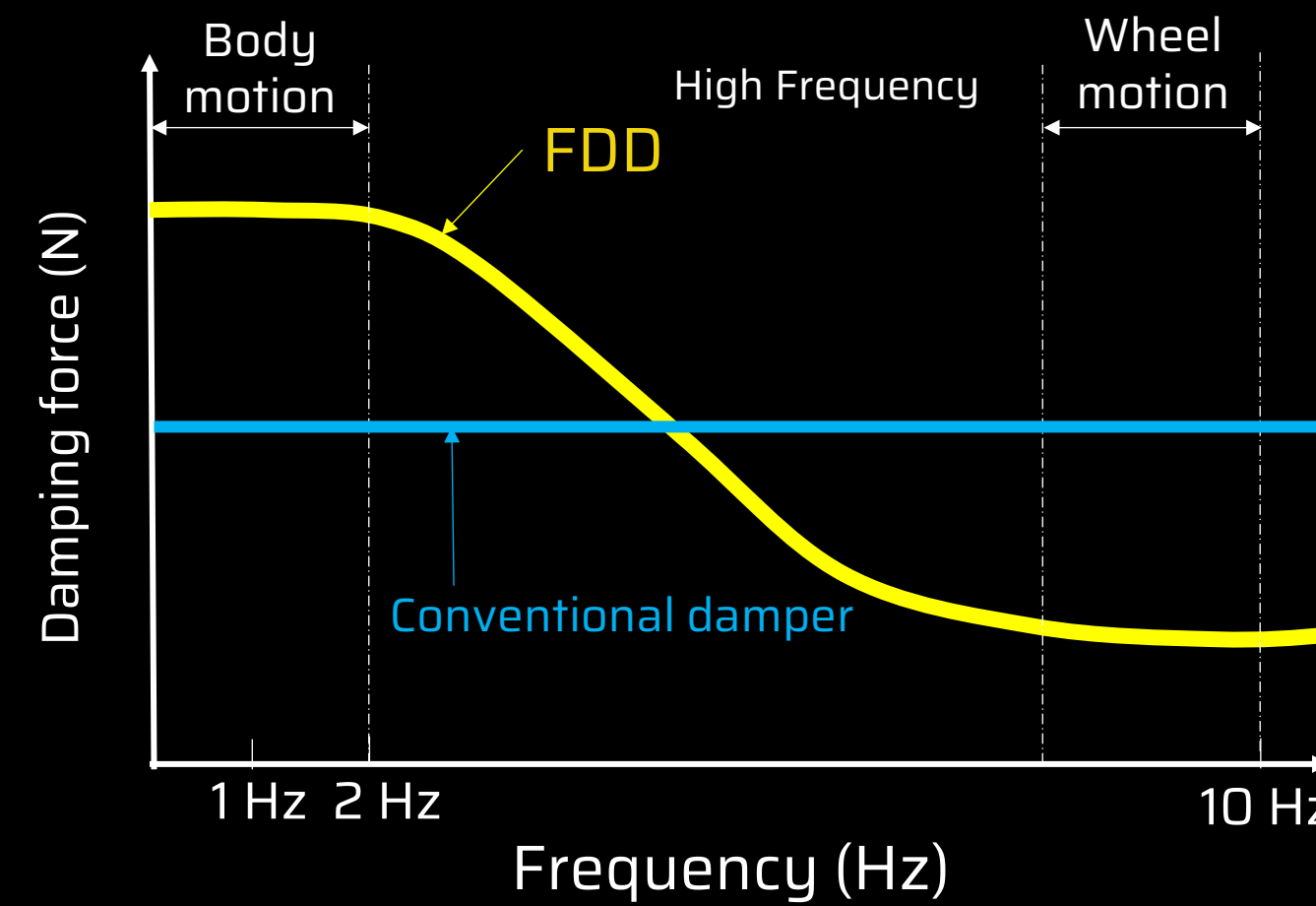

## HRS

(Hydraulic Rebound Stopper)



1<sup>st</sup> in Segment

## Ride Comfort

- Speed breakers
- Rough roads



# WGLYDE : Premium Steering Feel

## EPS Technology : Precise Steering Response & Linearity

**Steering rack moved closer to wheel center by 18 %**  
Enhanced precision, linearity & returnability

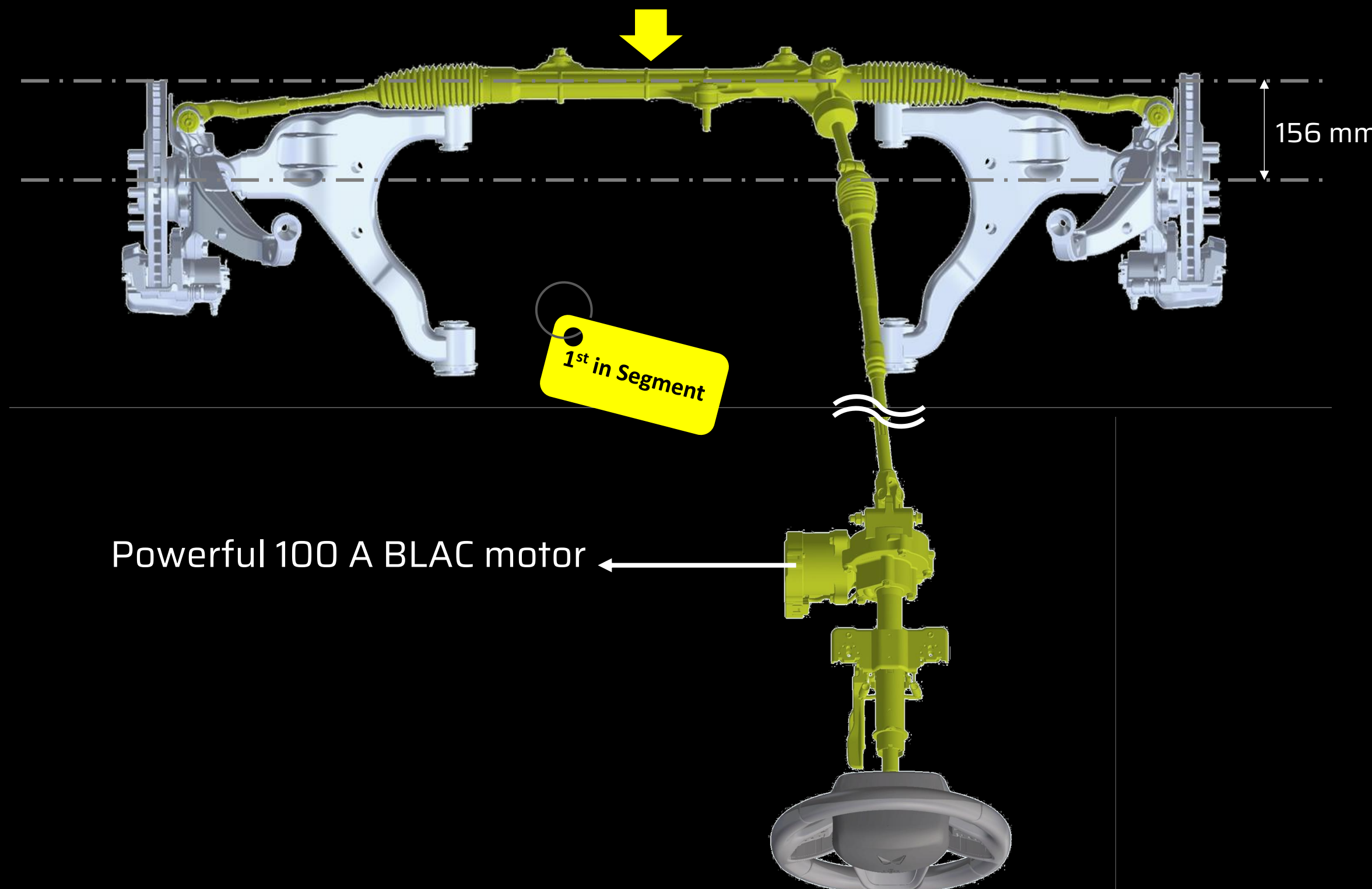

### Customer Benefits

- Ease of driving, parking & Maneuvering
- Efforts & Returnability
- Precise steering response, High linearity
- High confidence in cornering and lane change

# W.GLYDE : World-class RIDE

Ride Quality - Among the best !

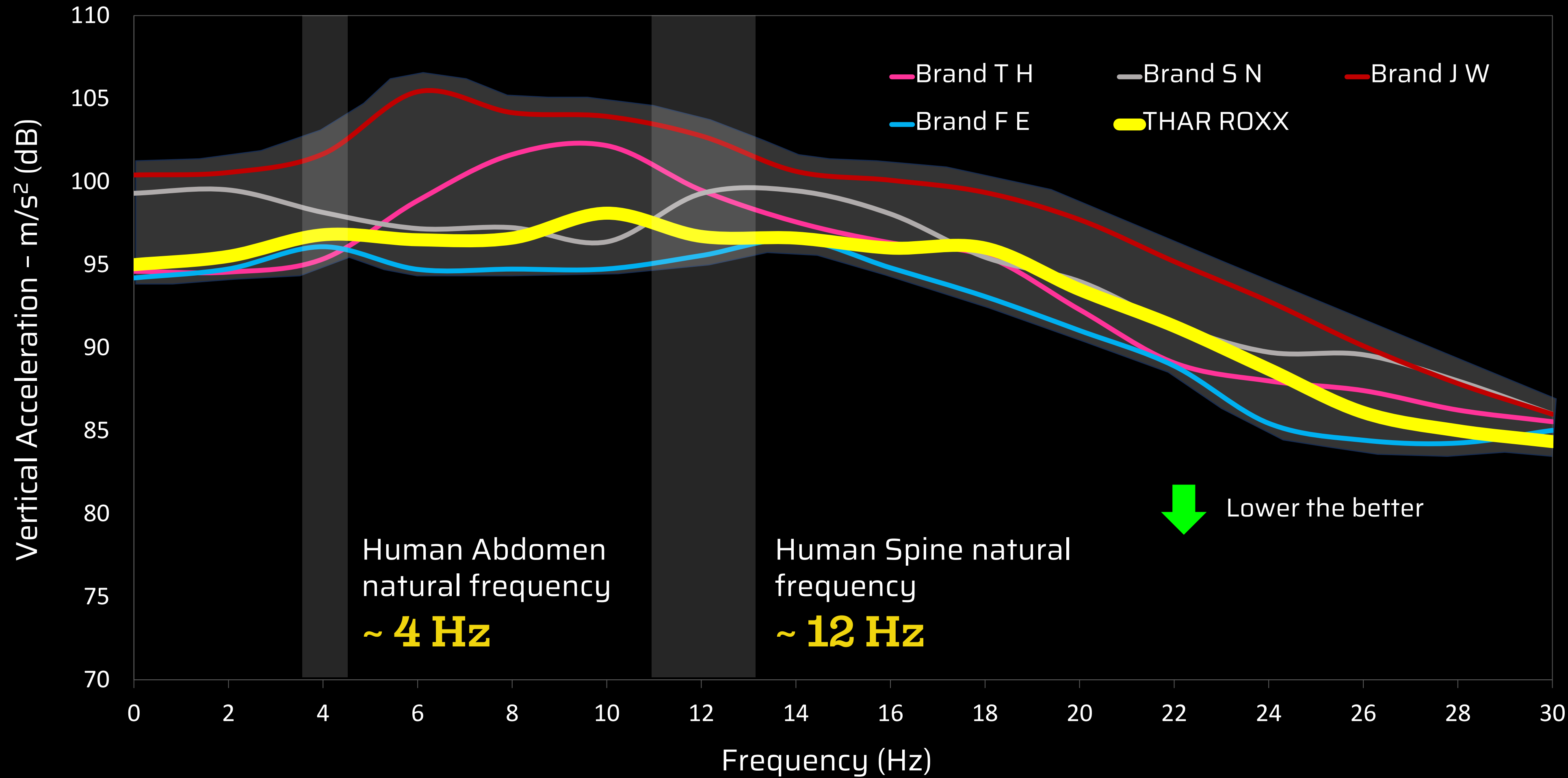

- Primary Ride : 0 to 2 Hz
- Secondary Ride : 8 to 20 Hz
- Wheel hop frequency
  - Front suspension : 10 Hz
  - Rear suspension : 18 Hz

# MGLYDE : World-class NVH

## Class leading Stiffness & Frequency

### High-Strength Steel

(More than 88 %)



Best in class

### Joinery Strengthening

(Better and wider overlap)

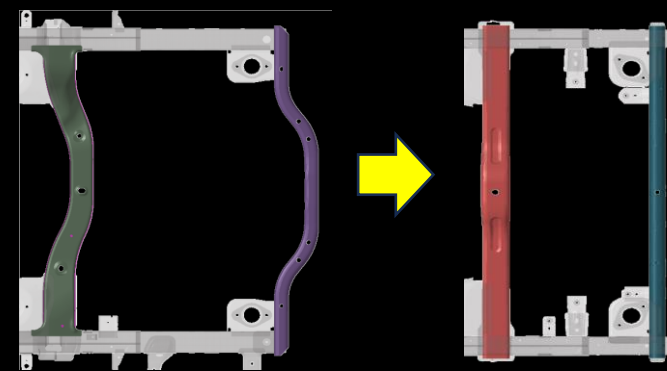

Frame  
mass

18 %

Lighter

Bending  
frequency

41 %

Higher

Torsional  
frequency

51 %

Higher

### Customer benefits :

Best-in-class NVH

Class leading Ride & Handling

5-star Crash performance

### High Section Modulus

(200 sections across 4m length)

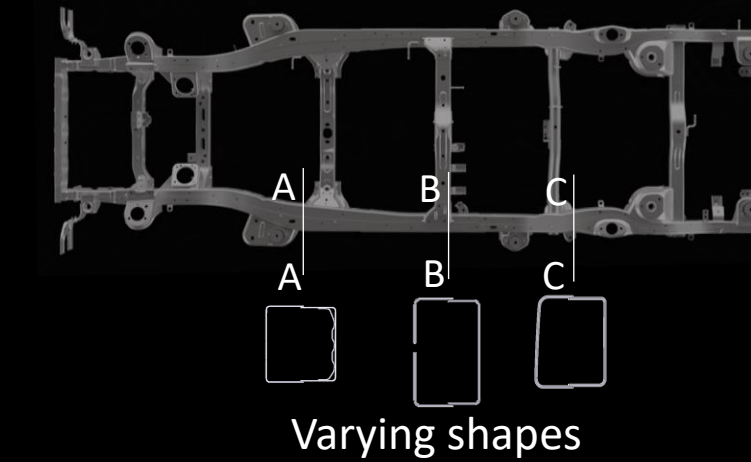

Varying shapes

1<sup>st</sup> in segment

### Lower Gauge Thickness

2.4 to 2.8 mm (Benchmark : ~ 3.0mm)

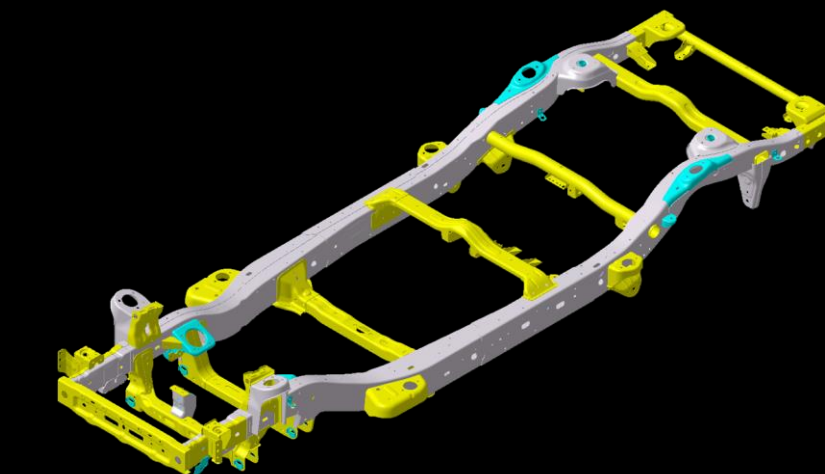

1<sup>st</sup> in segment

# MGLYDE : World-class NVH

## Class leading Stiffness & Frequency

### Torsional Frequency, Hz

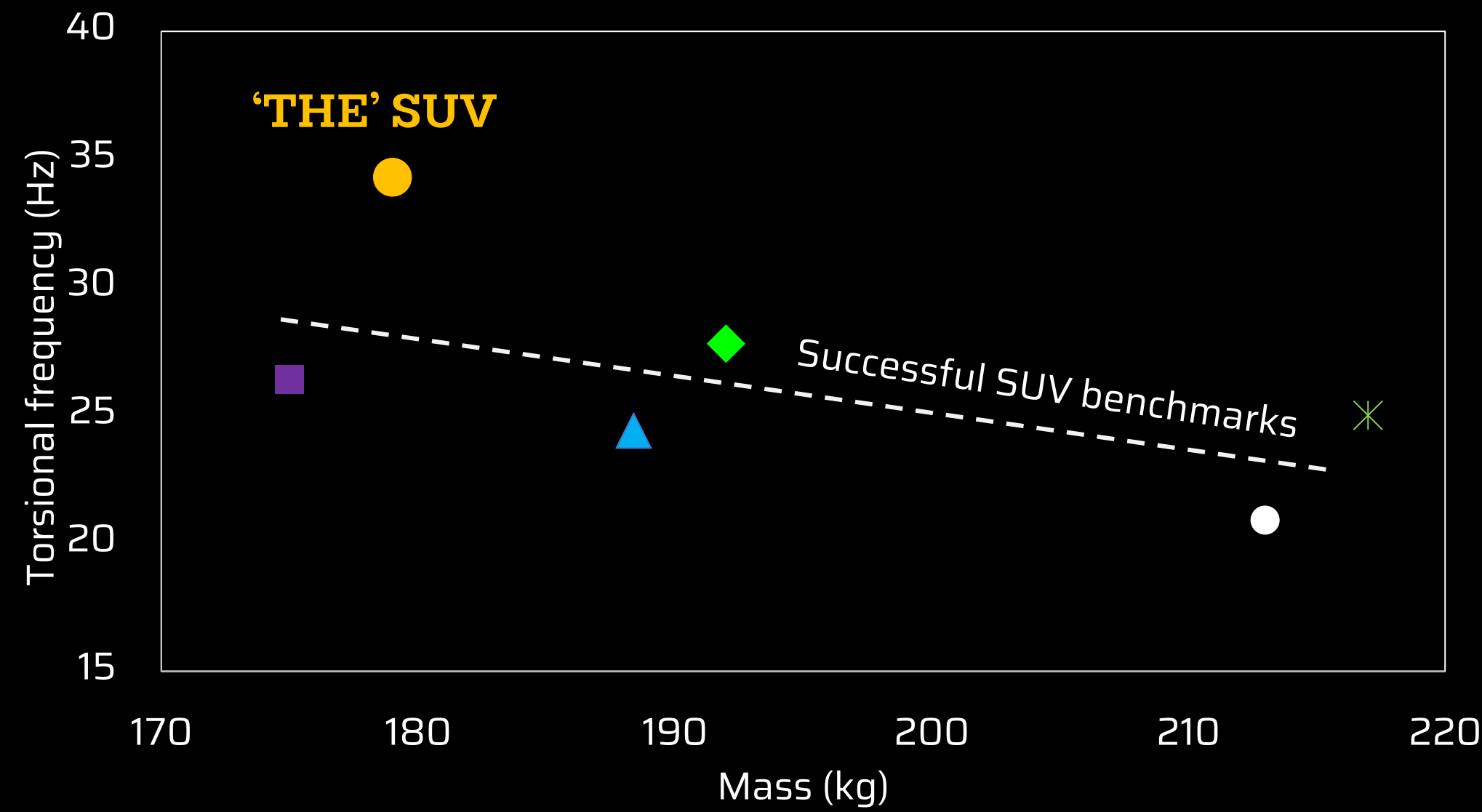

### Bending Frequency, Hz

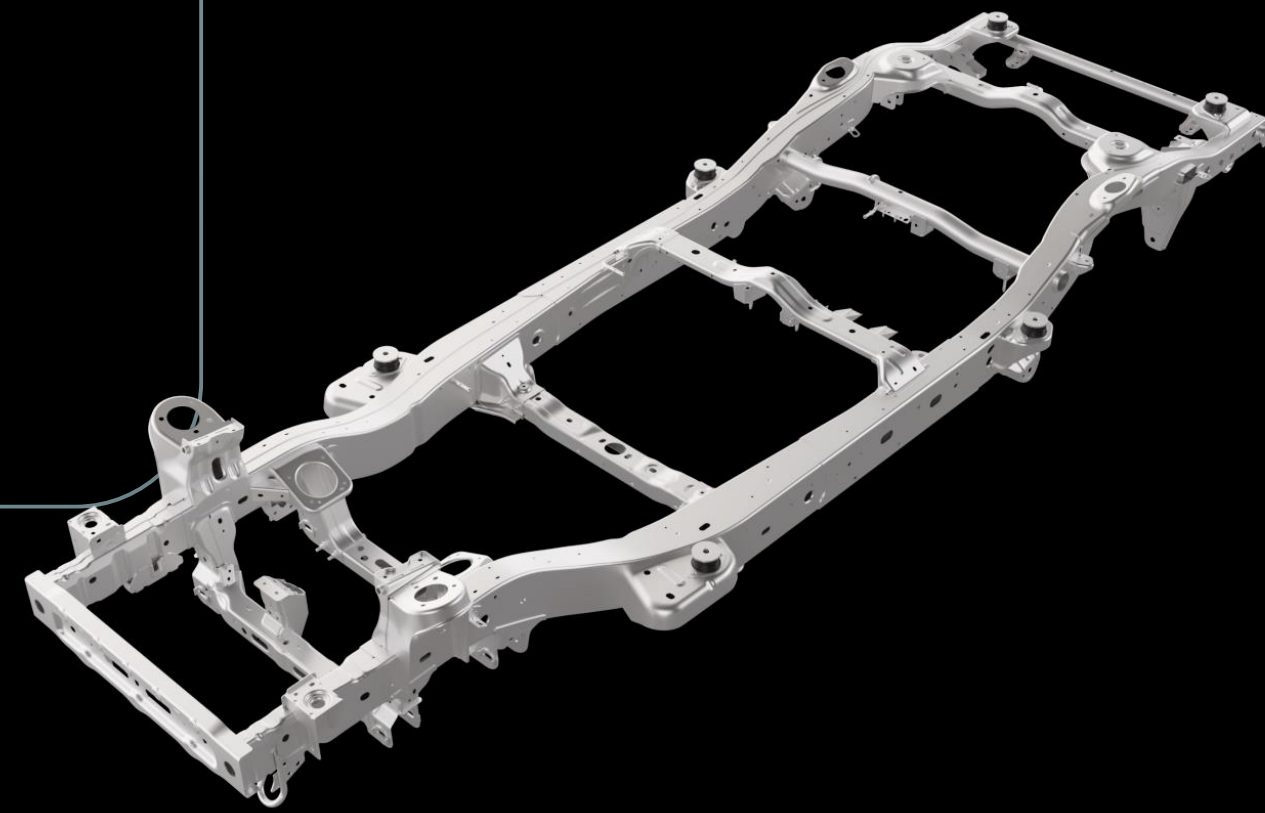
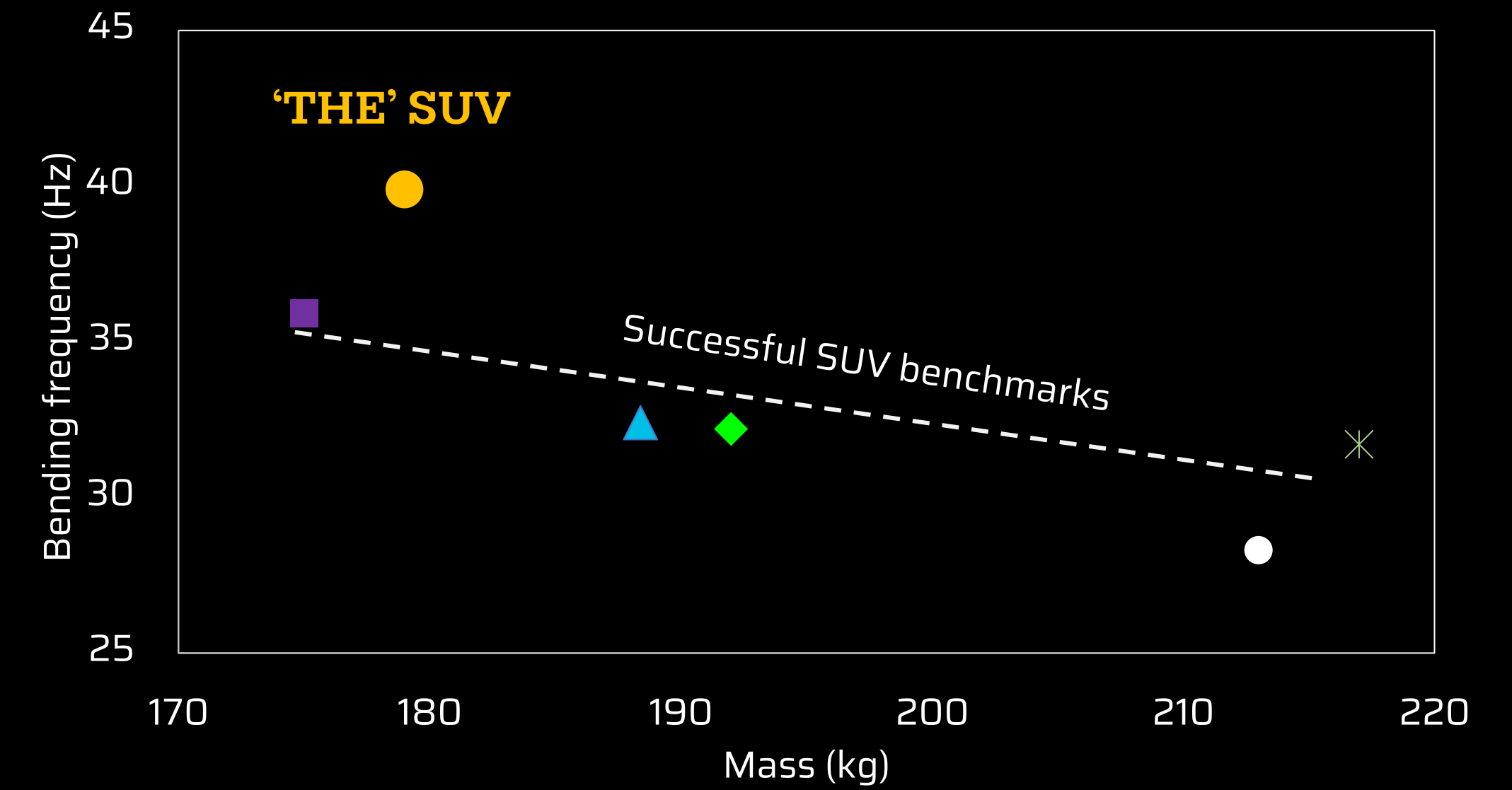

**'Frequency is a friend of refinement'**

# MG GLYDE : World-class NVH

All new full metal body with Unparalleled Stiffness

**Torsional stiffness :**  
**12.9 kNm/deg**  
(148 % better than benchmark)

Best in class

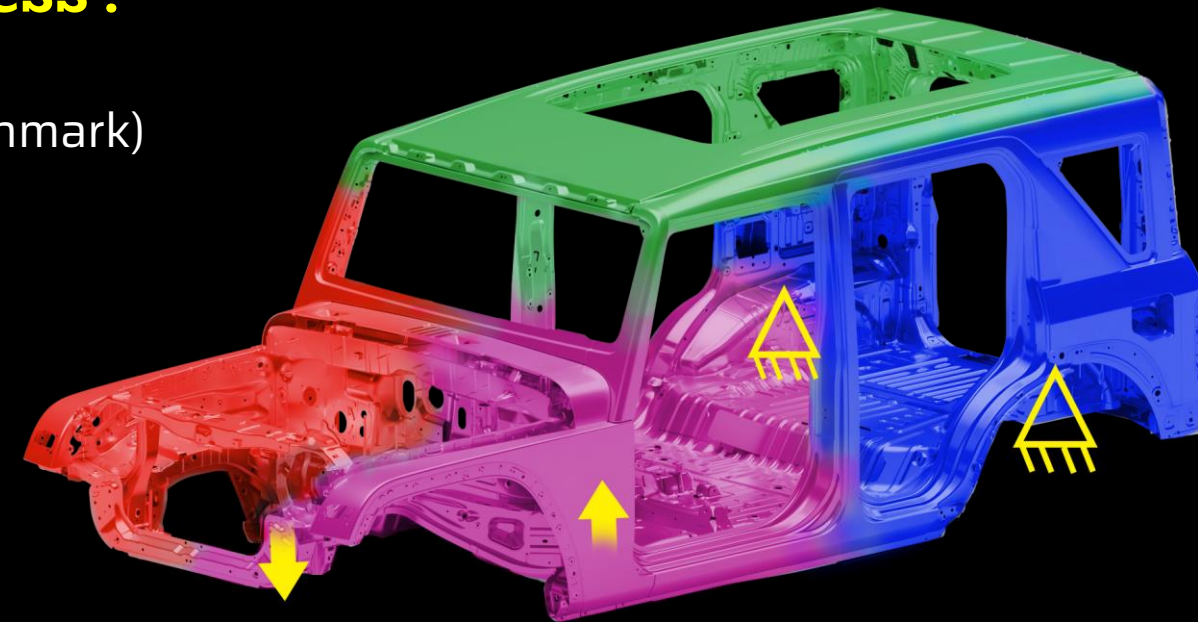

**Bending stiffness:**  
**9.0 kN/mm**  
(150 % better than benchmark)

Best in class

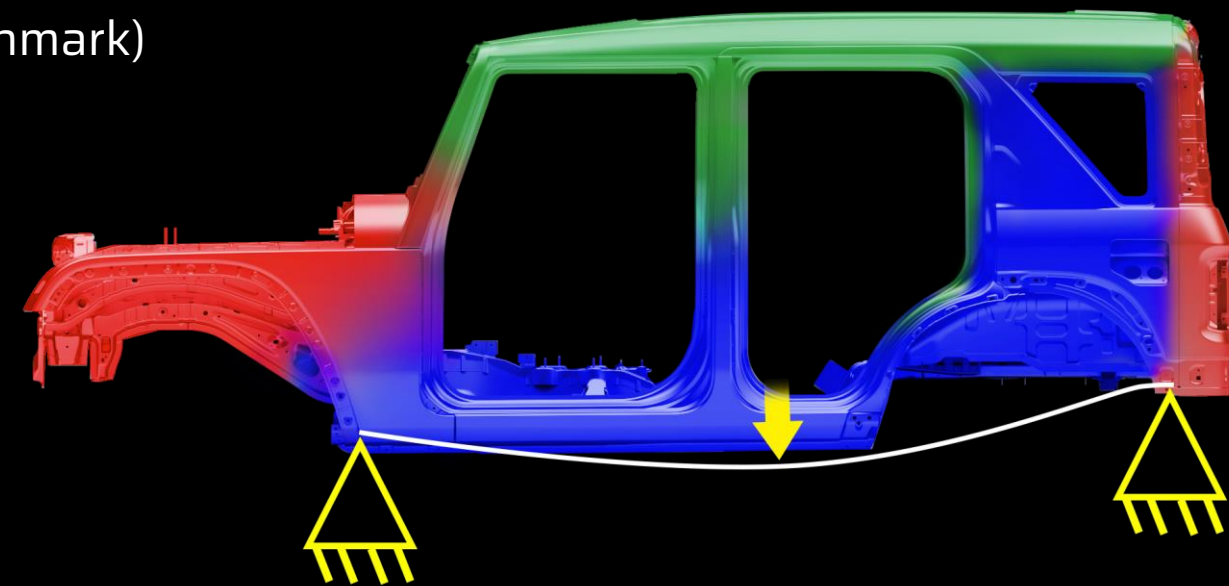

## High stiffness Ring Structure : NVH, Safety, Reliability

Enhanced joinery strength

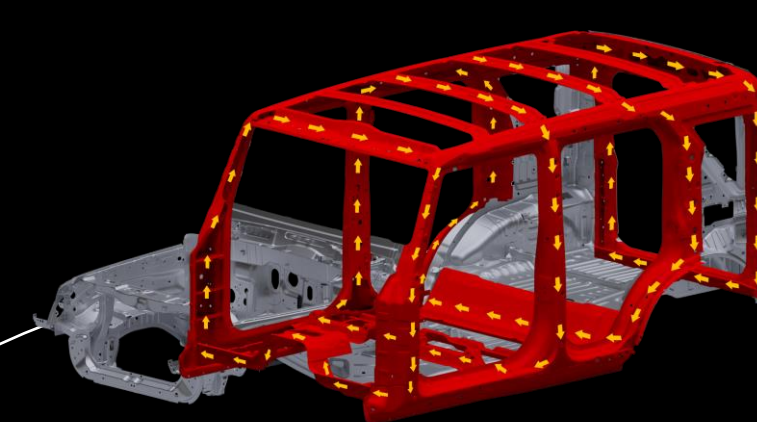
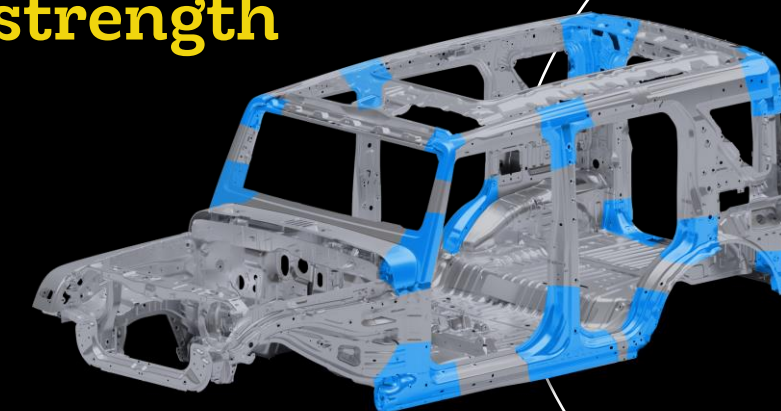

1<sup>st</sup> in segment

- Integrated roll-cage
- Weight same as benchmark with plastic roof

6227 Spot welds

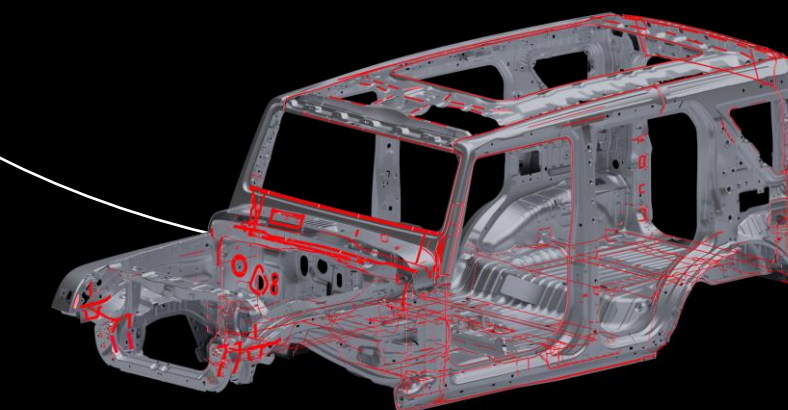
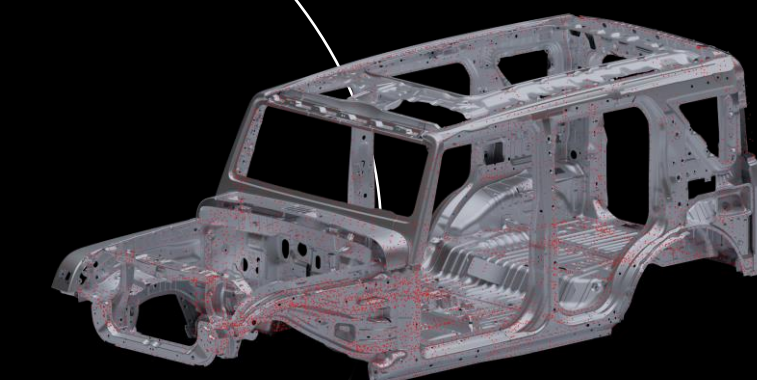

136.8 m length sealer

**'Ring Structure brings Stiffness'**  
**'Stiffness brings Quietness'**

# MGLYDE : CLASS LEADING NVH

## Quiet & Comfortable Cabin

**Loudness at Driver-ear Location (Diesel)**

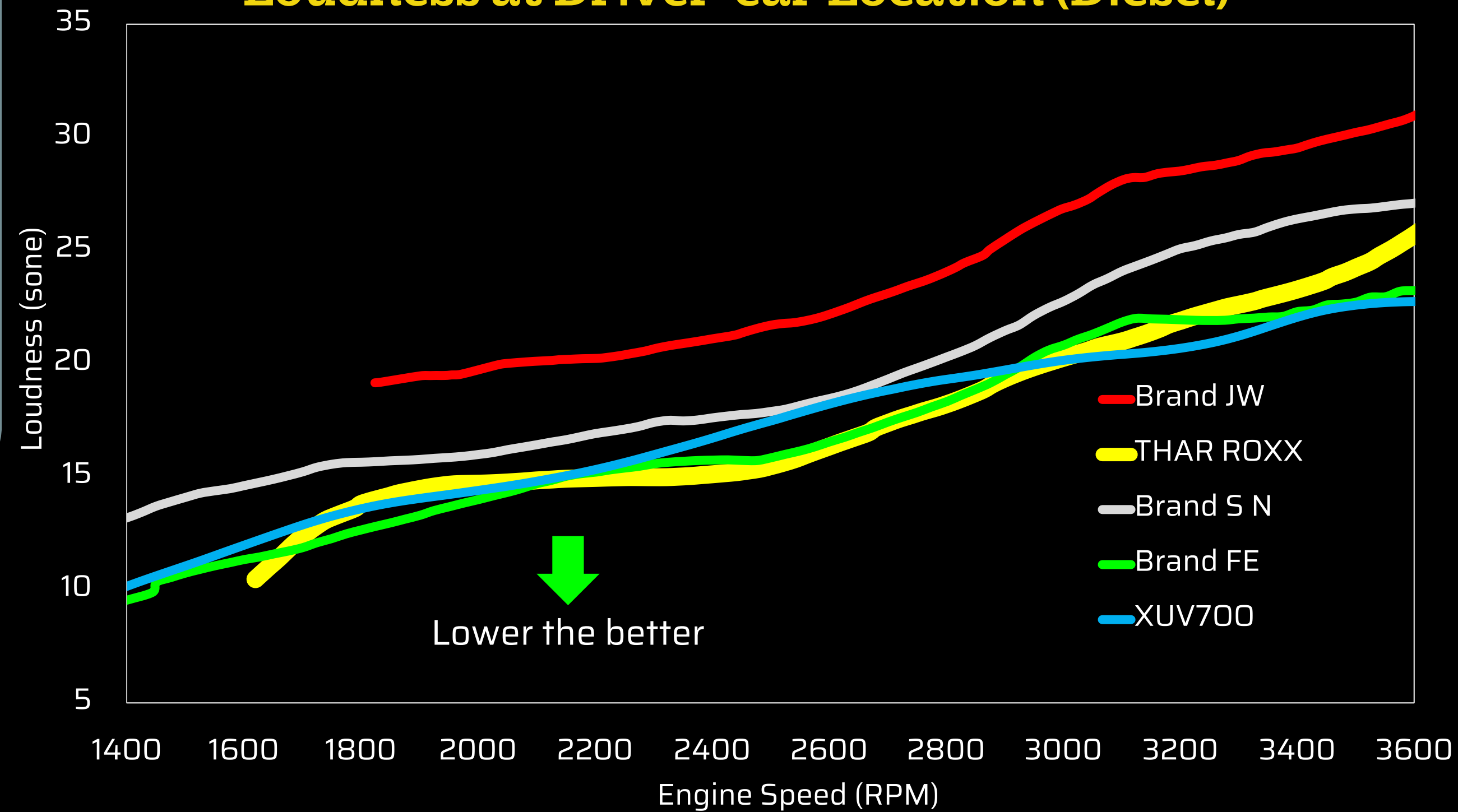

**Sound quality : Articulation Index (Diesel)**

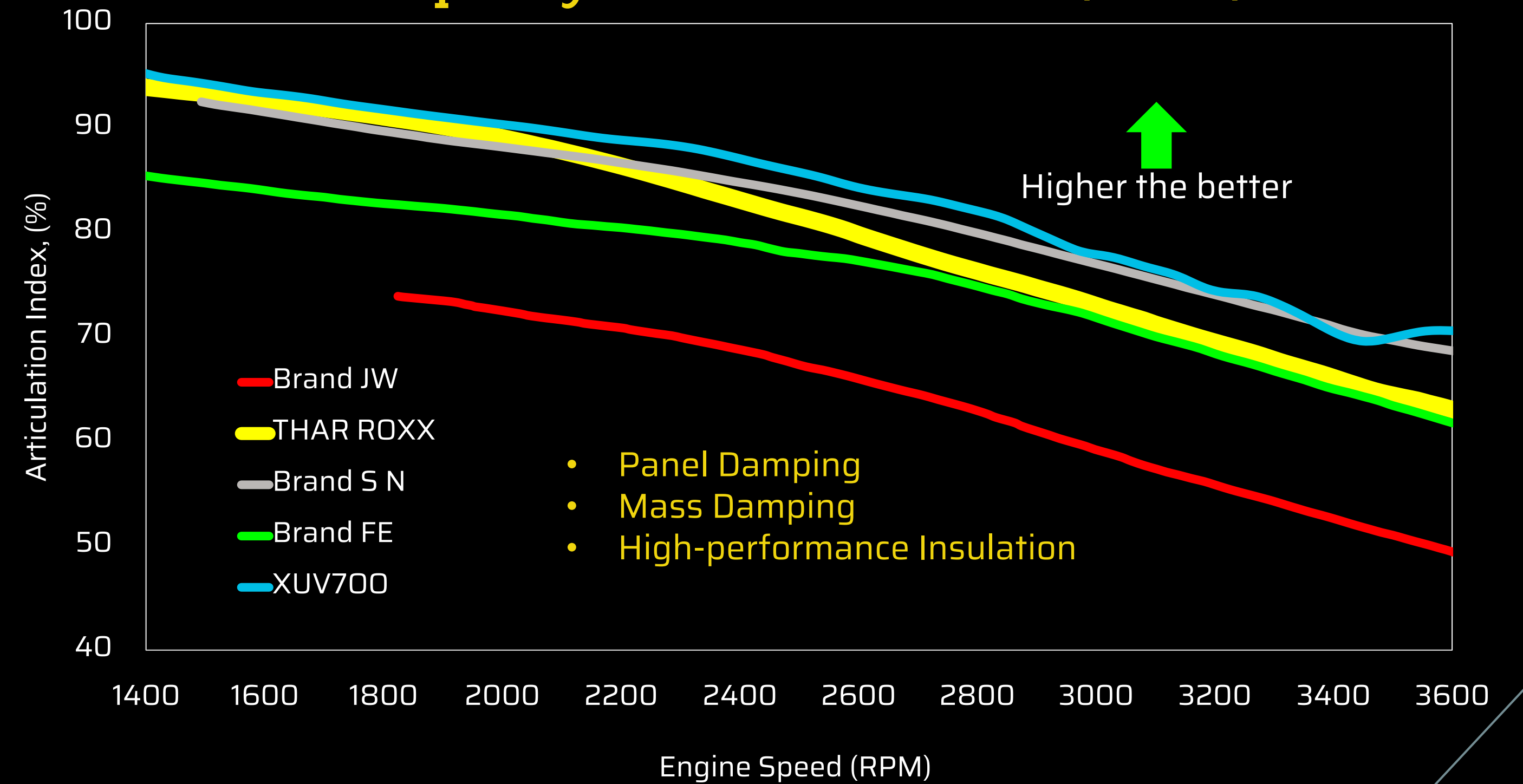

- Low idle noise : Gasoline 39 dBA, Diesel 41 dBA
- Uncontrolled cabin air leakage - 48 lps (25% better than benchmark)

A photograph of a desert canyon with layered rock walls and a sandy floor. The text "GET OFF THE TAR" is overlaid in white, bold, serif font. The canyon walls show distinct horizontal sedimentary layers, and the floor is composed of smooth, undulating sand dunes. The lighting is warm, suggesting a sunset or sunrise, with shadows cast across the rock surfaces.

**GET  
OFF THE TAR**

# 'THE' SUV : CAPABILITY PAR EXCELLENCE

Legendary ADR angles & Water-fording depth



650 mm  
fording depth

41.7°

23.9°

36.1°



# 'THE' SUV : CAPABILITY PAR EXCELLENCE

**GLYDE**: Superior Wheel Torque, ELD & BLD

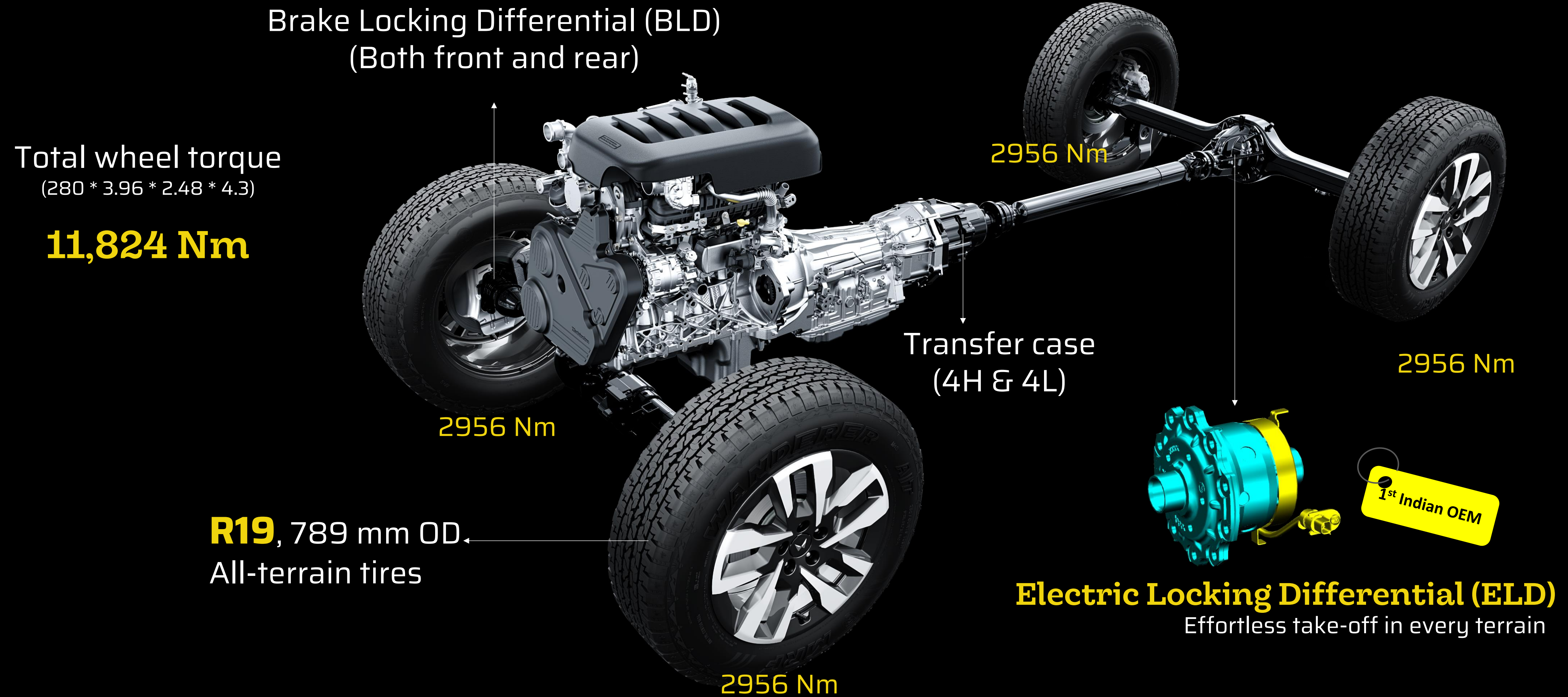

# 'THE' SUV : LOADED WITH TECHNOLOGY

## Conquer Every Terrain

### Terrain Modes



- Sand
- Mud
- Snow

### IntelliTurn Assist (ITA)

1<sup>st</sup> in segment



- Intelligent braking of inner wheel in 4-L mode
- Reduction of TCD by 15 %

### CrawlSmart

1<sup>st</sup> in segment



- Automatic control of engine, brake and transmission.
- Sail through every obstacle

**POWER ON**

# 'THE' SUV : Exhilarating Performance

High Performance Gasoline & Diesel Engines



## G20 TGD mStallion Engine

- 129 kW (177 PS) @ 5000 rpm
- 380 Nm @ 1750 - 3000 rpm
- 350 bar GDI system
- Electric actuated Turbo charger



## D22 mHawk Engine

- 129 kW (175 PS) @ 3500 rpm
- 370 Nm @ 1500 - 3000 rpm
- 1600 bar common rail system
- New Generation turbo charger

# 'THE' SUV : Exhilarating Performance

## High Performance Gasoline & Diesel Engines

### G20 TGDI Gasoline AT

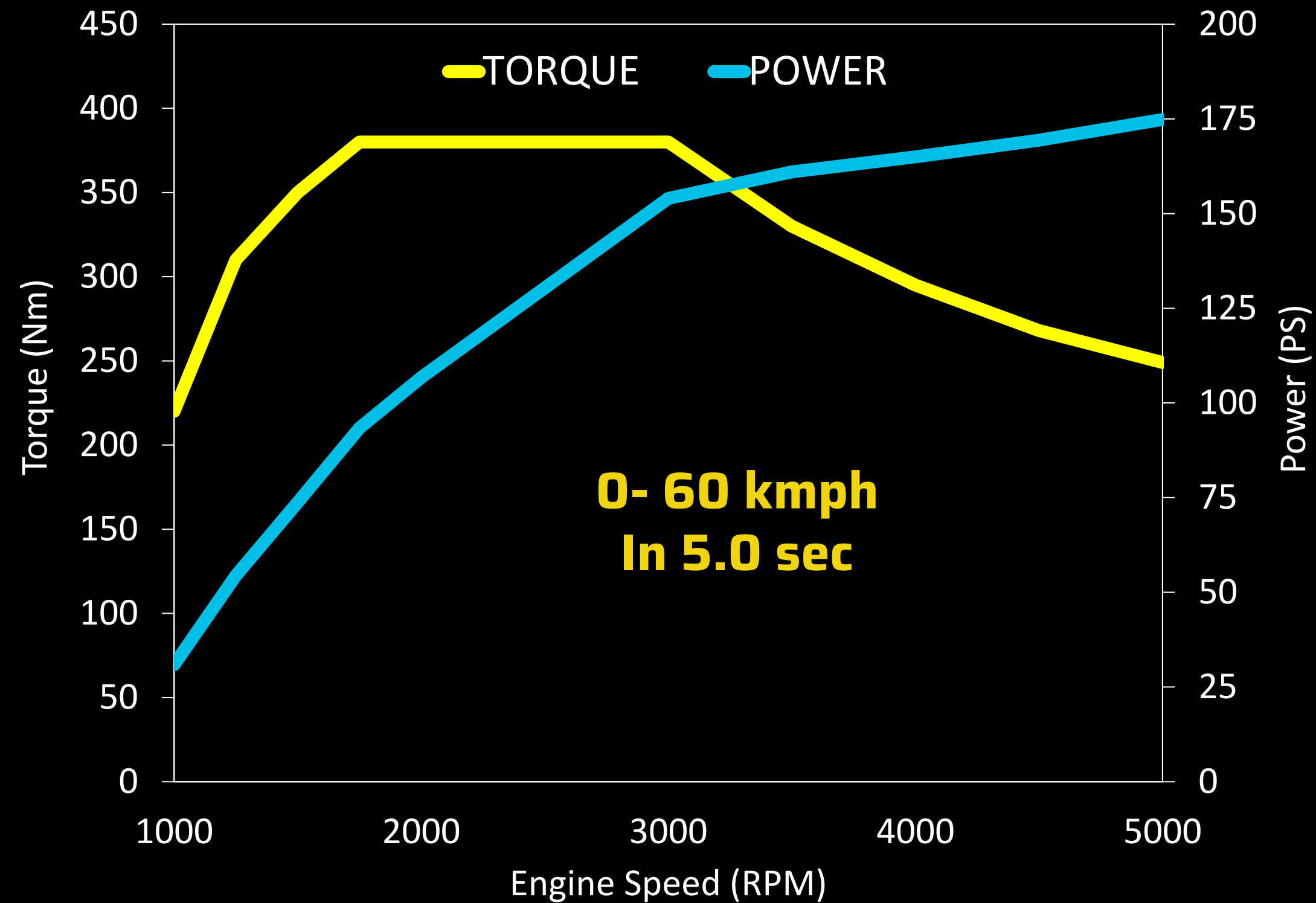

### D22 Diesel AT

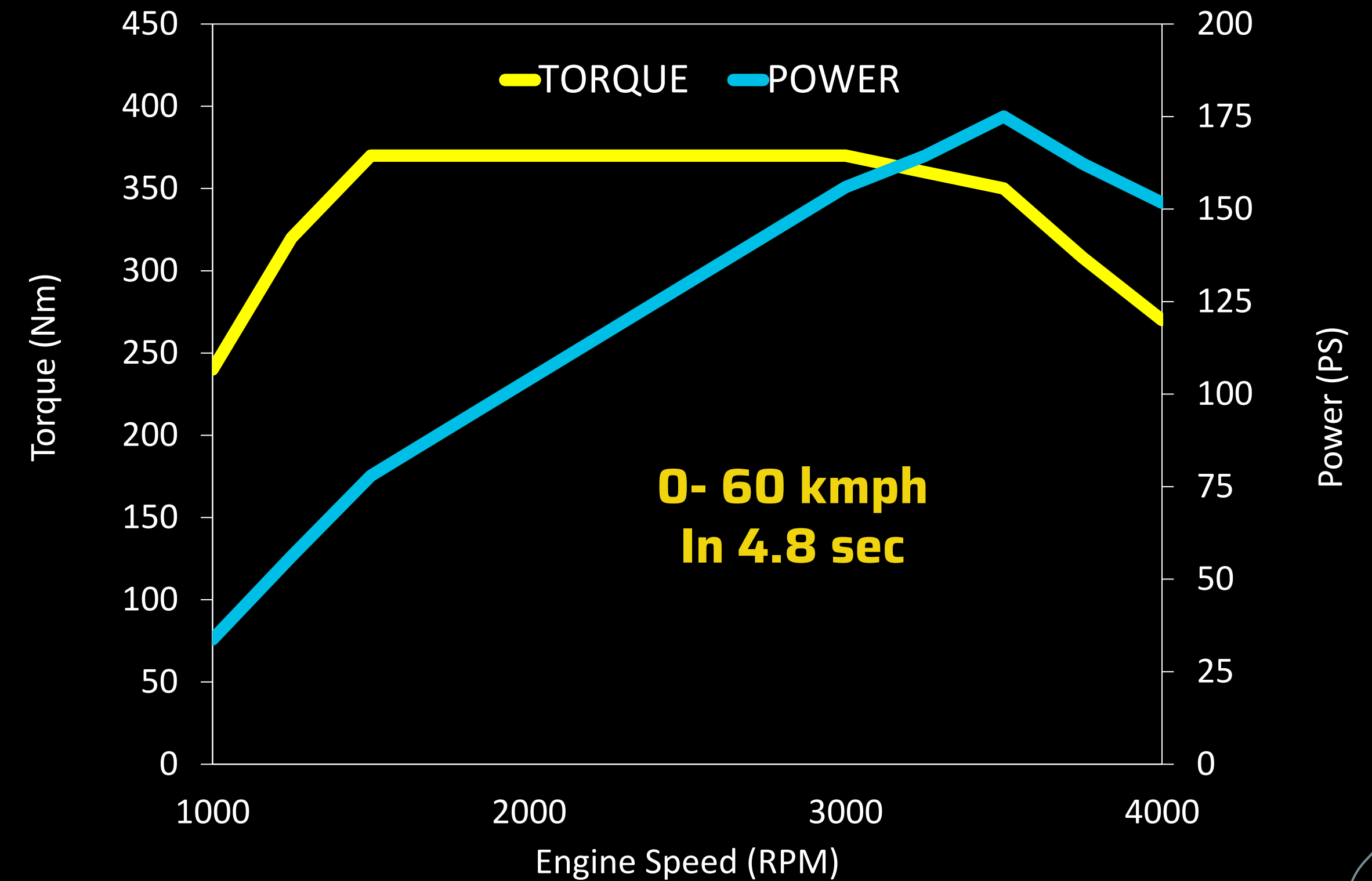

- Unparalleled low-end torque for acceleration performance and off-road lugging
- Wide range of max torque for highway cruising with minimum downshifting

# 'THE' SUV : Exhilarating Performance

## Premium and Effortless Transmissions

### 6 Speed AISIN\* Automatic Transmission

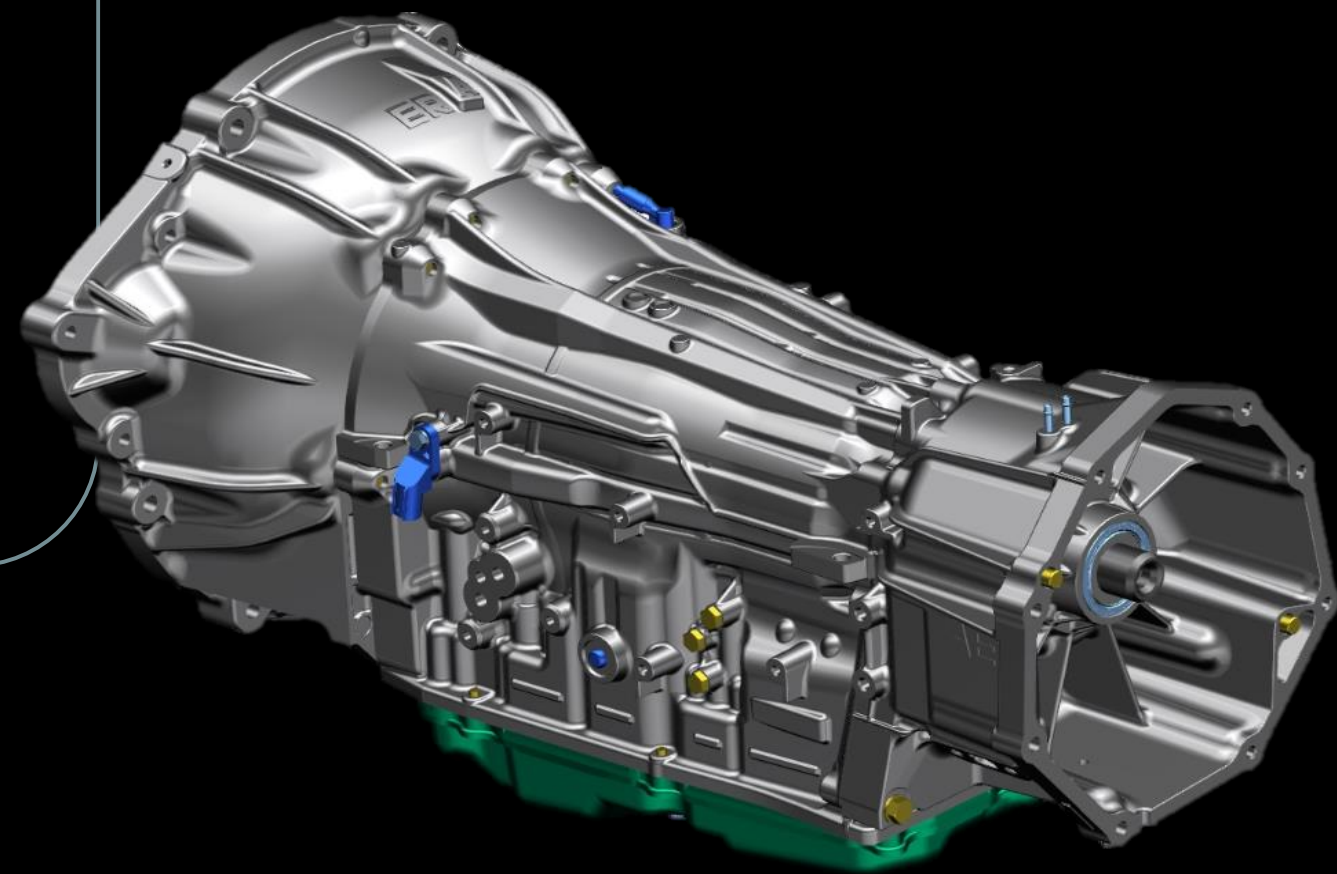

- Best-in-class Fuel Economy
- Globally Proven Automatic Transmission from AISIN
- Best-in-class NVH

### 6 Speed Manual Transmission

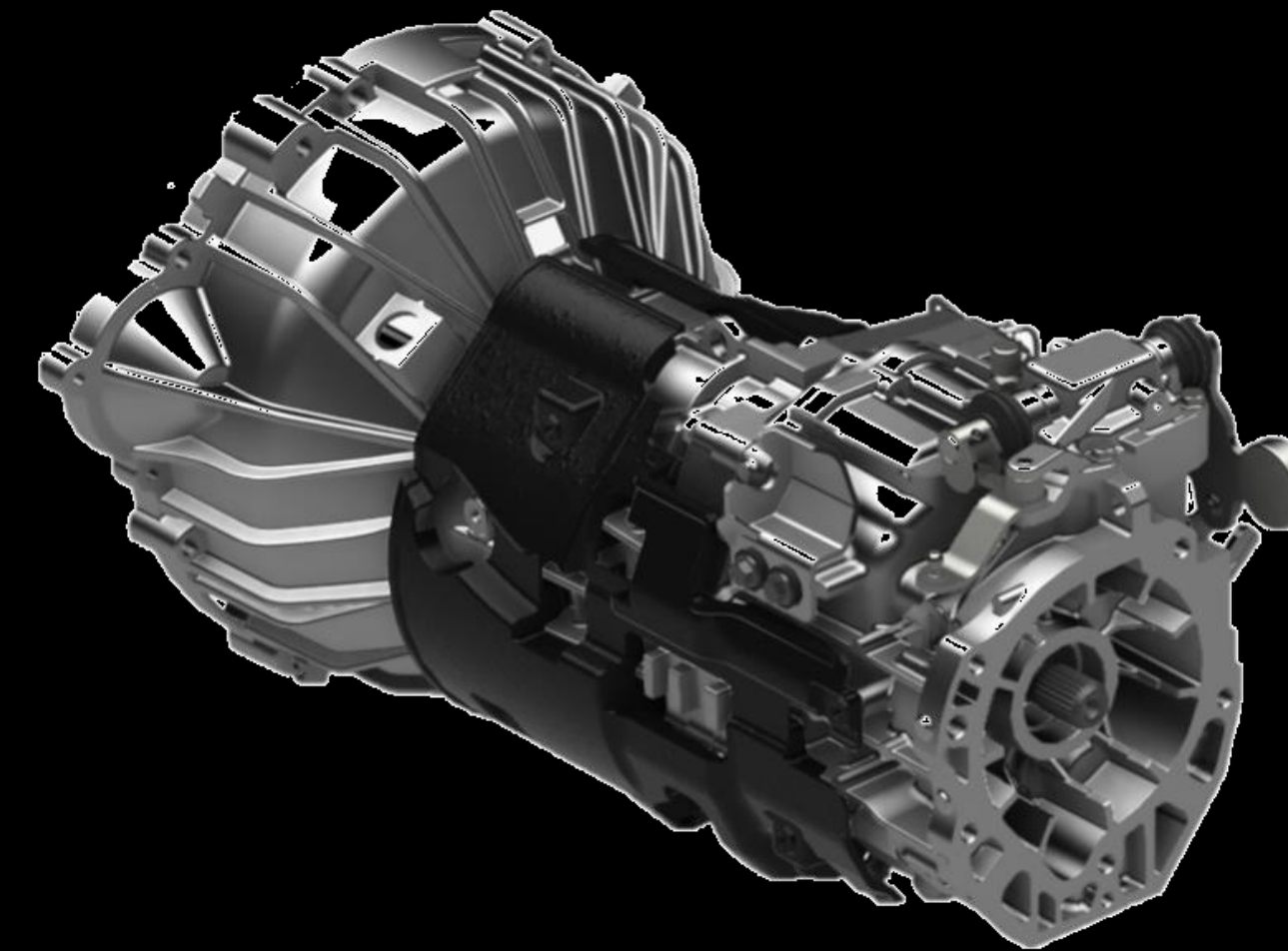

- Best in class NVH
- Cable shifter with dampers
- Fully synchronized gearbox

\*Japanese technology introduced in XUV700

# THE ULTIMATE SAFE MACHINE

## Superior Crash Performance

- Impact force : 227 kN (22.7 ton) at 64 kmph
- Designed to protect against peak deceleration of 32 g
- Frontal crash energy absorption : 363 kJ

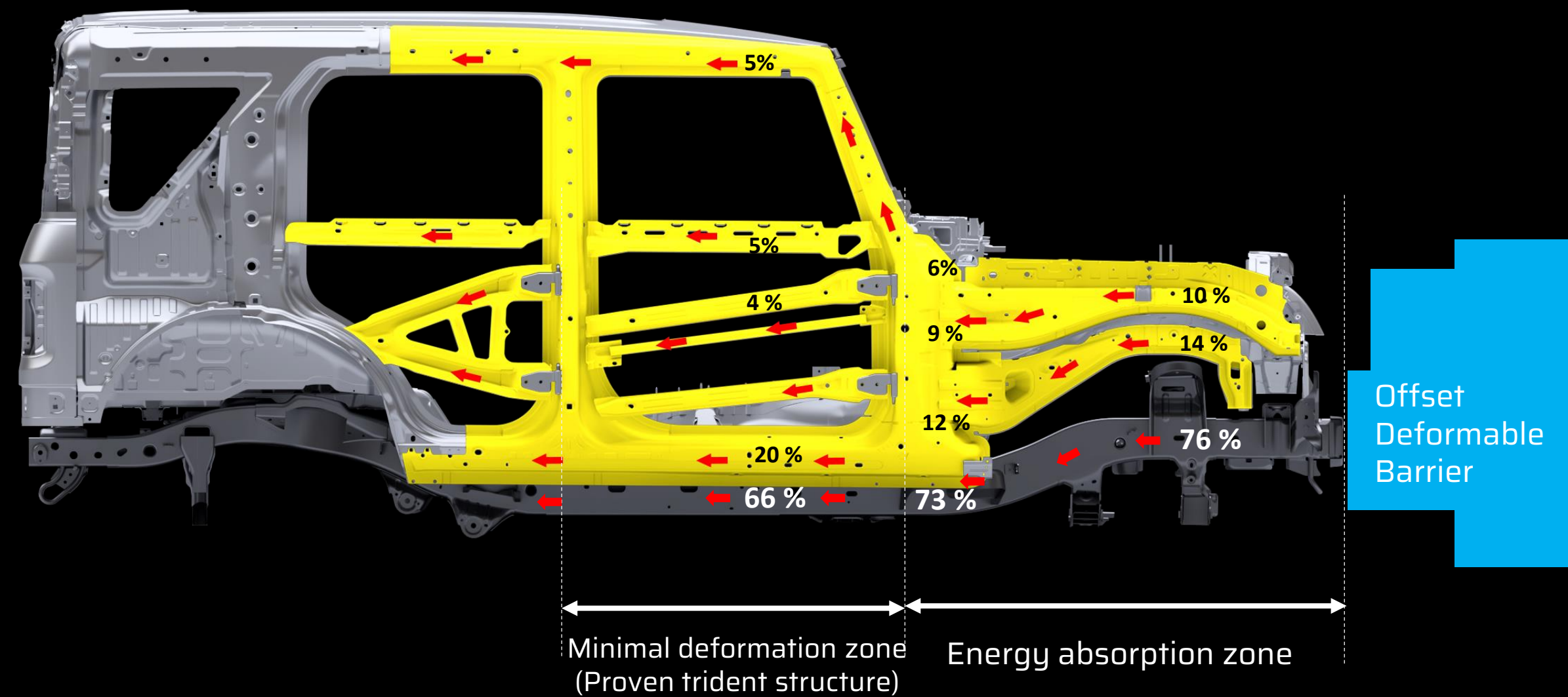

### Pulse Diagram

Frontal Offset Crash - 64 kmph

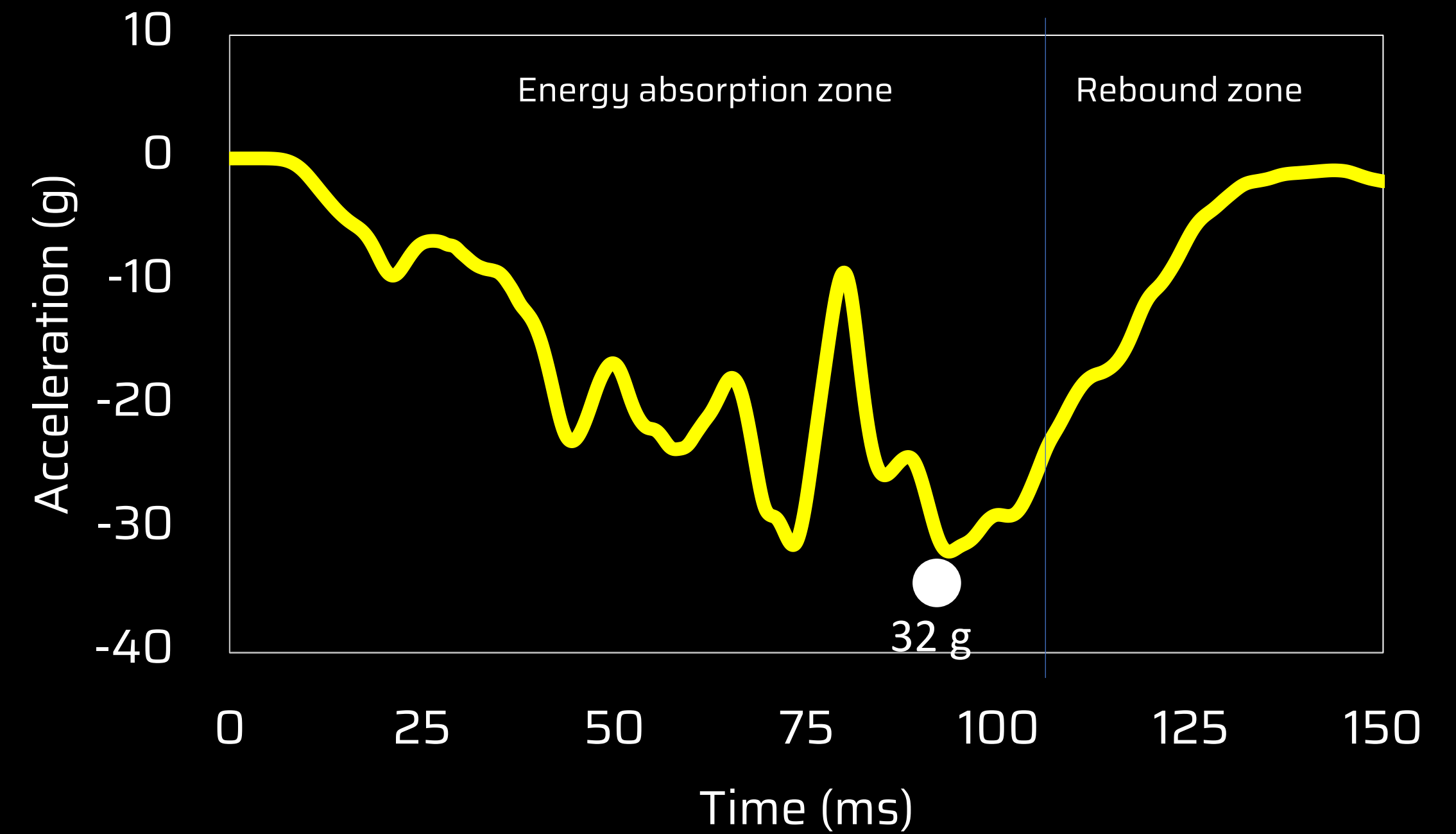

**'Stable structure, Safe cocoon'**

# THE ULTIMATE SAFE MACHINE

Comprehensive Safety Package

35+

## STANDARD SAFETY FEATURES



- 6 Airbags
- 3-point seat belt for all seats
- Seat-belt reminders for all seats
- Passenger airbag ON/OFF for child safety
- ISO-FIX child seats with top-tether
- Seat belt height adjuster for front row.



# THE ULTIMATE SAFE MACHINE

State-of-the art ESP suite

ESP 9.3 system with improved BLDC motor



Time to lock (TTL) < 550 ms @ 0.9 g

## Dynamic Safety Functions

- Vehicle Dynamics Control (VDC)
- Traction Control System (TCS)
- Roll Over Mitigation (ROM)

## Other Value-add Functions

- Hill Hold Control (HHC)
- Hill Descent Control (HDC)
- Brake Disc Wiping (BDW)
- Electronic Brake Prefill (EBP)

The background image shows a modern architectural space with curved concrete beams and a large glass wall. The lighting is dim, creating a moody atmosphere. The text is centered in the middle of the frame.

**ROCK**  
**THE LUXE LIFE**



# Interior & Colour Material Finish Design

**mahindra**  
GLOBAL DESIGN

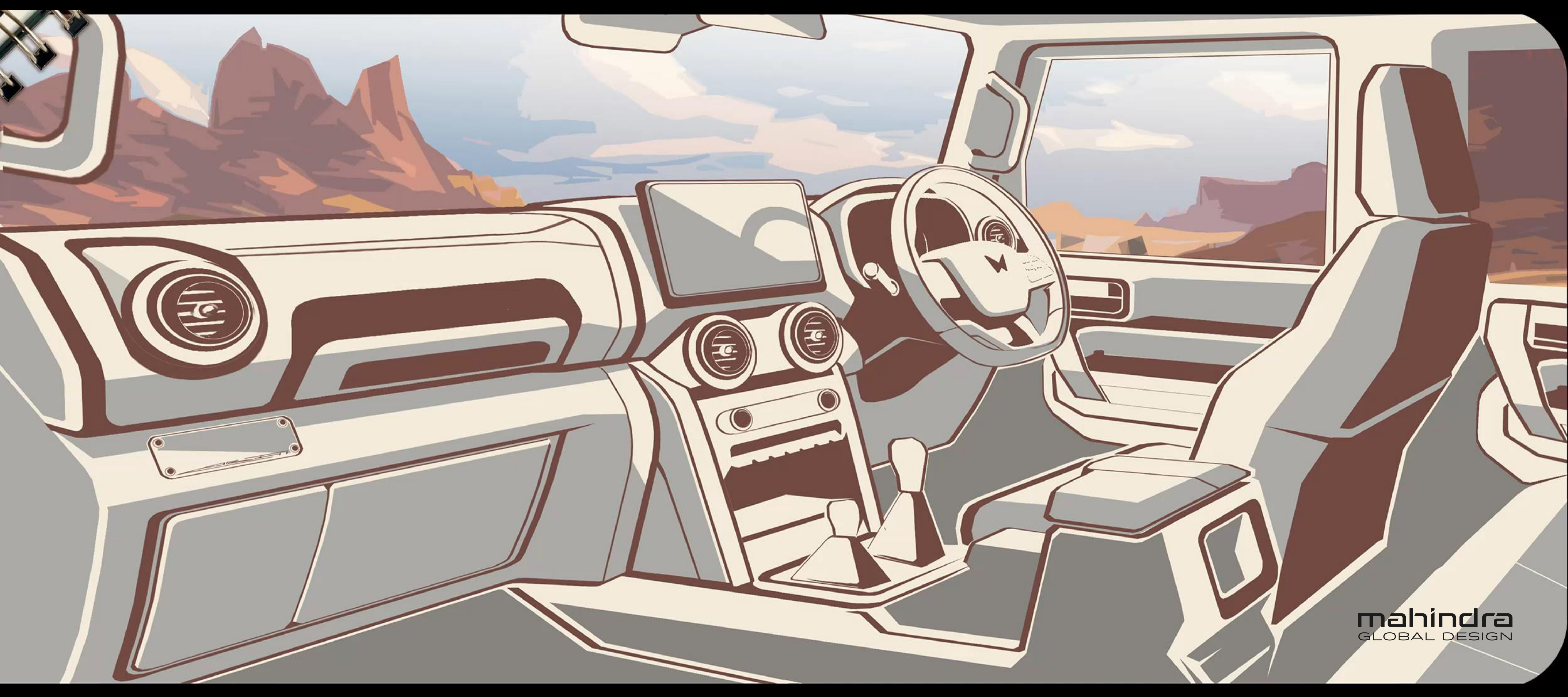

**mahindra**  
GLOBAL DESIGN



**mahindra**  
GLOBAL DESIGN



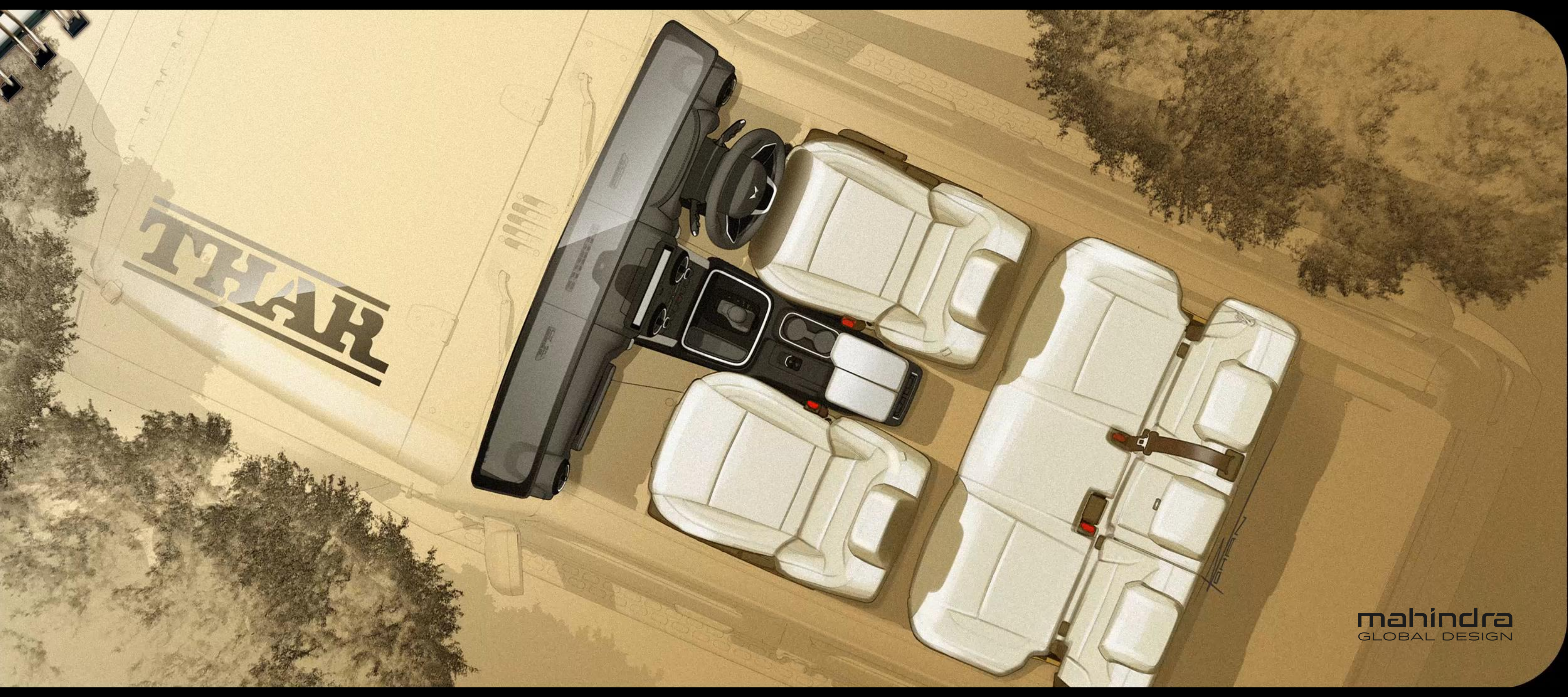

**THAR**

**mahindra**  
GLOBAL DESIGN









**mahindra**  
GLOBAL DESIGN



**mahindra**  
GLOBAL DESIGN



# 'THE' SUV : ROCK THE LUXE LIFE

## Wheelbase & Couple Distance

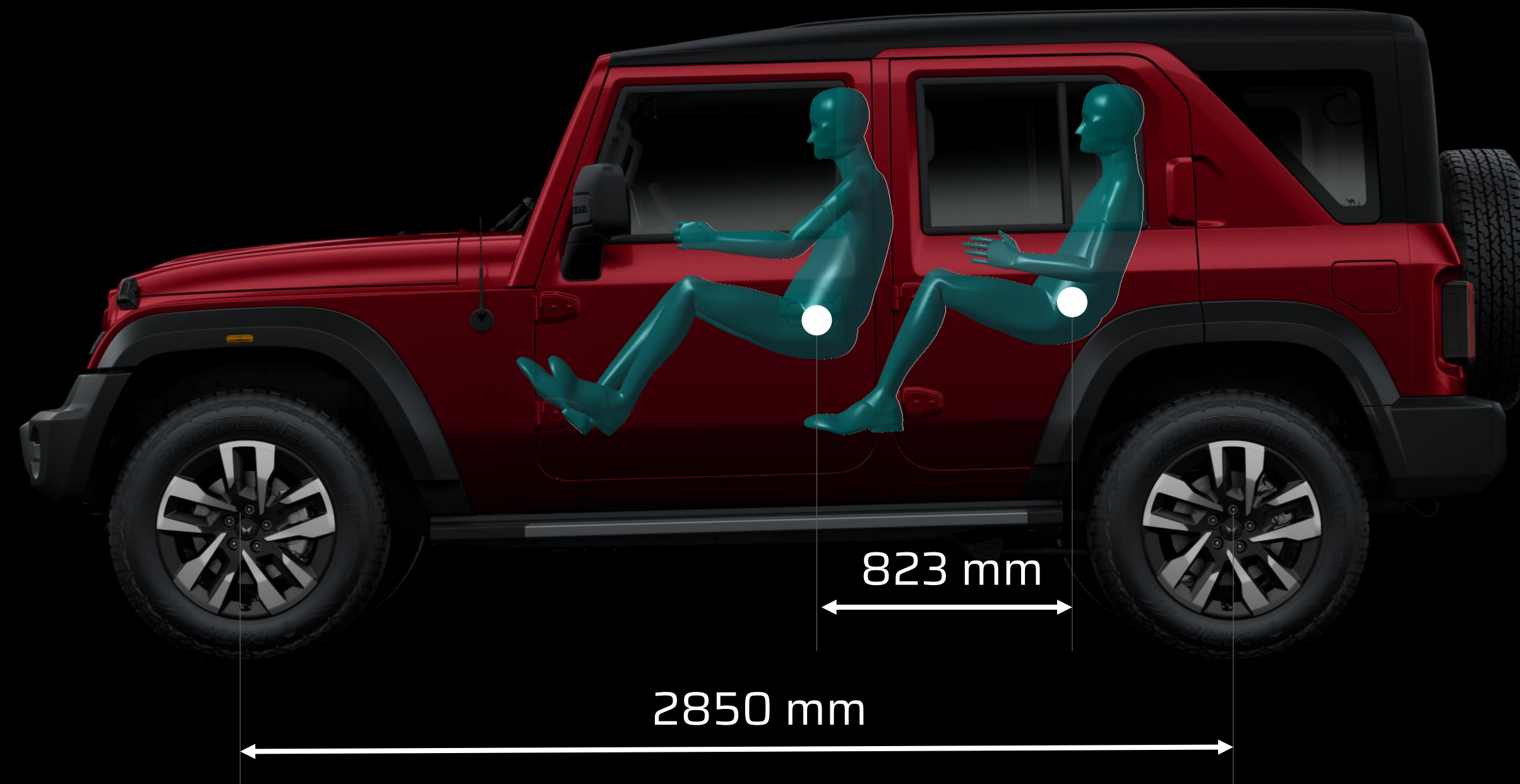

### PARAMETER

### THAR ROXX

### #1 C-Segment SUV Player

Wheelbase (mm)

2850

2610

Couple Distance(mm)

823

811

# 'THE' SUV : ROCK THE LUXE LIFE

## Best-in-class Cabin Roominess

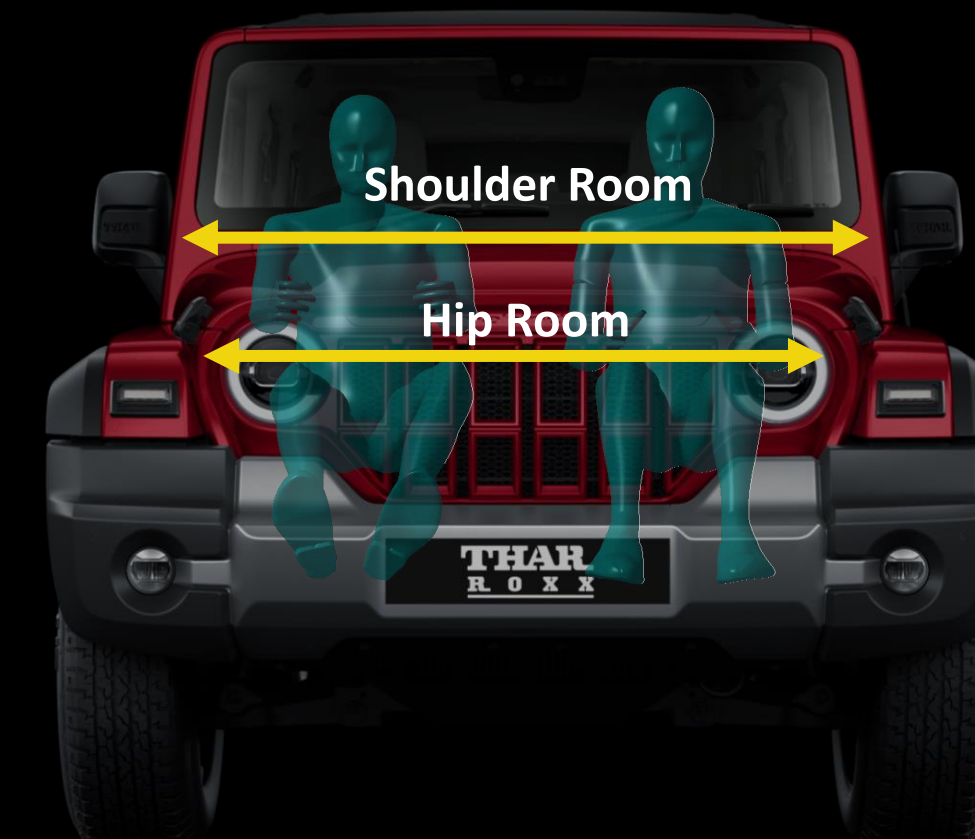
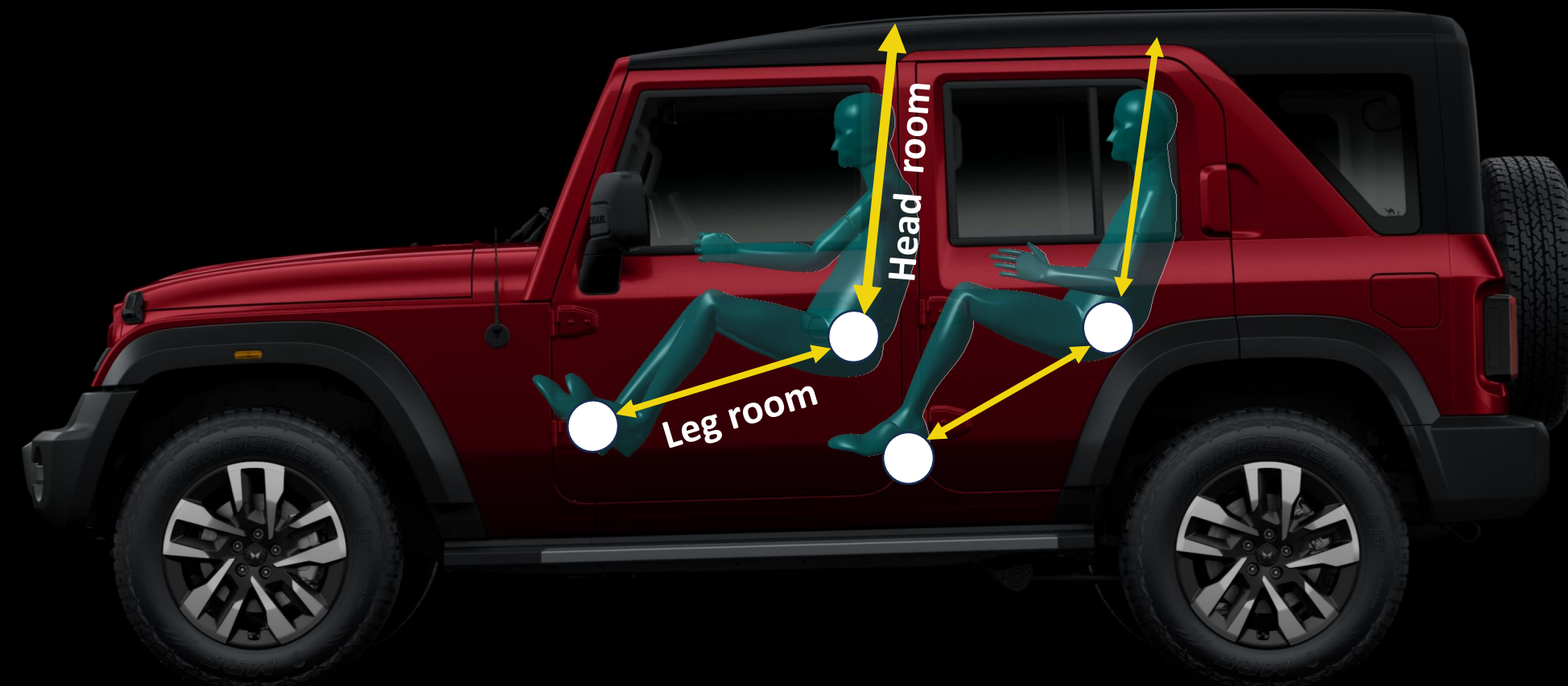

### PARAMETER

### THAR ROXX

### #1 C-Segment SUV Player

Leg Room (1<sup>st</sup> / 2<sup>nd</sup> row)

1055 / 930

1053 / 900

Head room (1<sup>st</sup> / 2<sup>nd</sup> row)

1021 / 985

1011 / 973

Shoulder room (1<sup>st</sup> / 2<sup>nd</sup> row)

1418 / 1434

1404 / 1367

Hip Room (1<sup>st</sup> / 2<sup>nd</sup> row)

1354 / 1343

1356 / 1322

# 'THE' SUV : ROCK THE LUXE LIFE

Huge and versatile boot space



60:40 foldable backrest

644 liters  
(up to roof)

## PARAMETER

## THAR ROXX

## #1 C-Segment SUV Player

Luggage volume (up to back rest) (VDA - ISO V211)

447

319

Luggage volume (up to roof) (ISO V215)

644

443



**Turn  
Heads**



**Don't Just  
Ride, Glide**



**Get Off  
The Tar**



**Power  
On**



**Rock the  
Luxe Life**



# 'THE' SUV : Tough yet Sophisticated

Skyroof : Experience 'Freedom' like never before

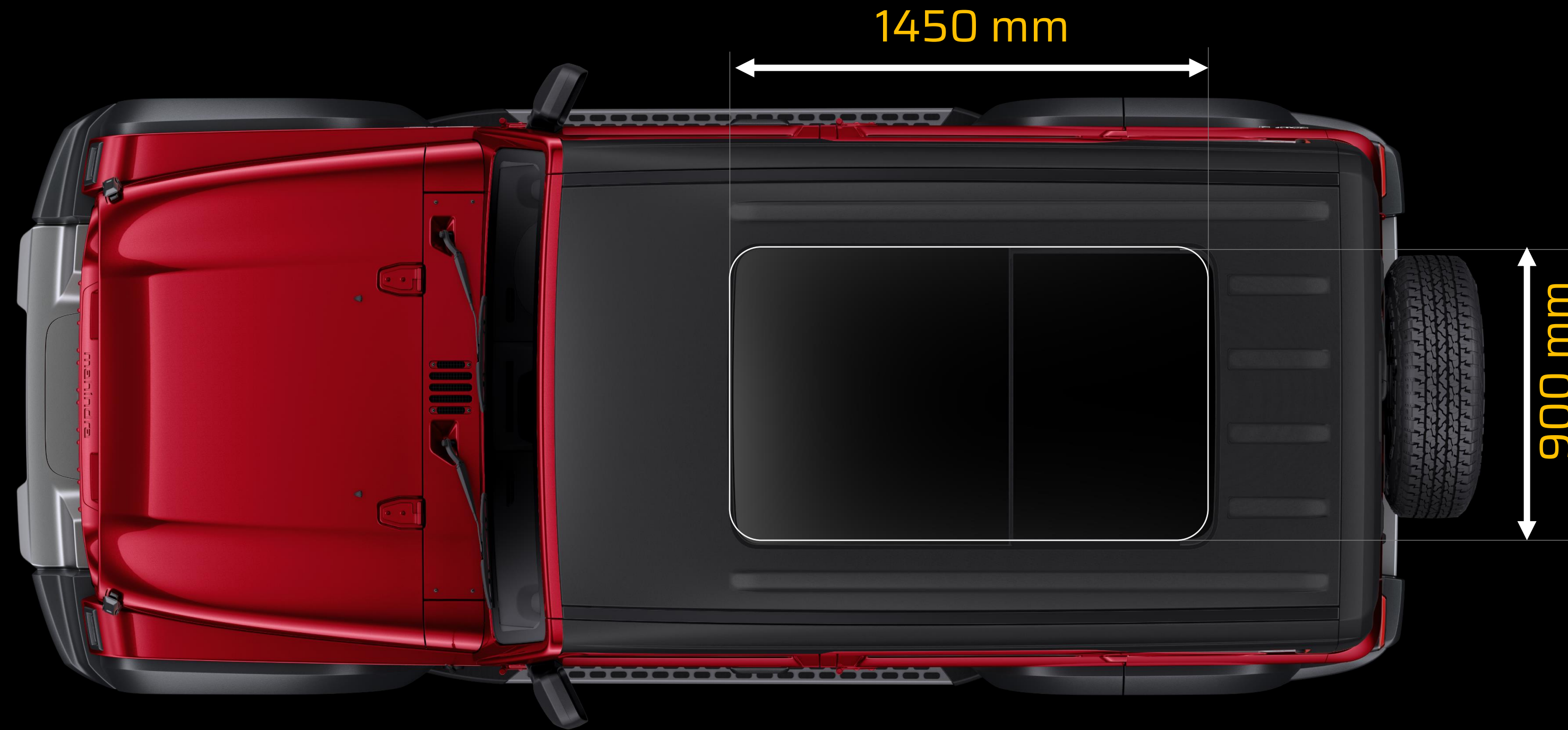

- Glass dimension : 1450 x 900 mm
- Open to Sky : 636 x 731 mm

# 'THE' SUV : Tough yet Sophisticated

ADAS : Level 2

## 1R 1V ADAS System

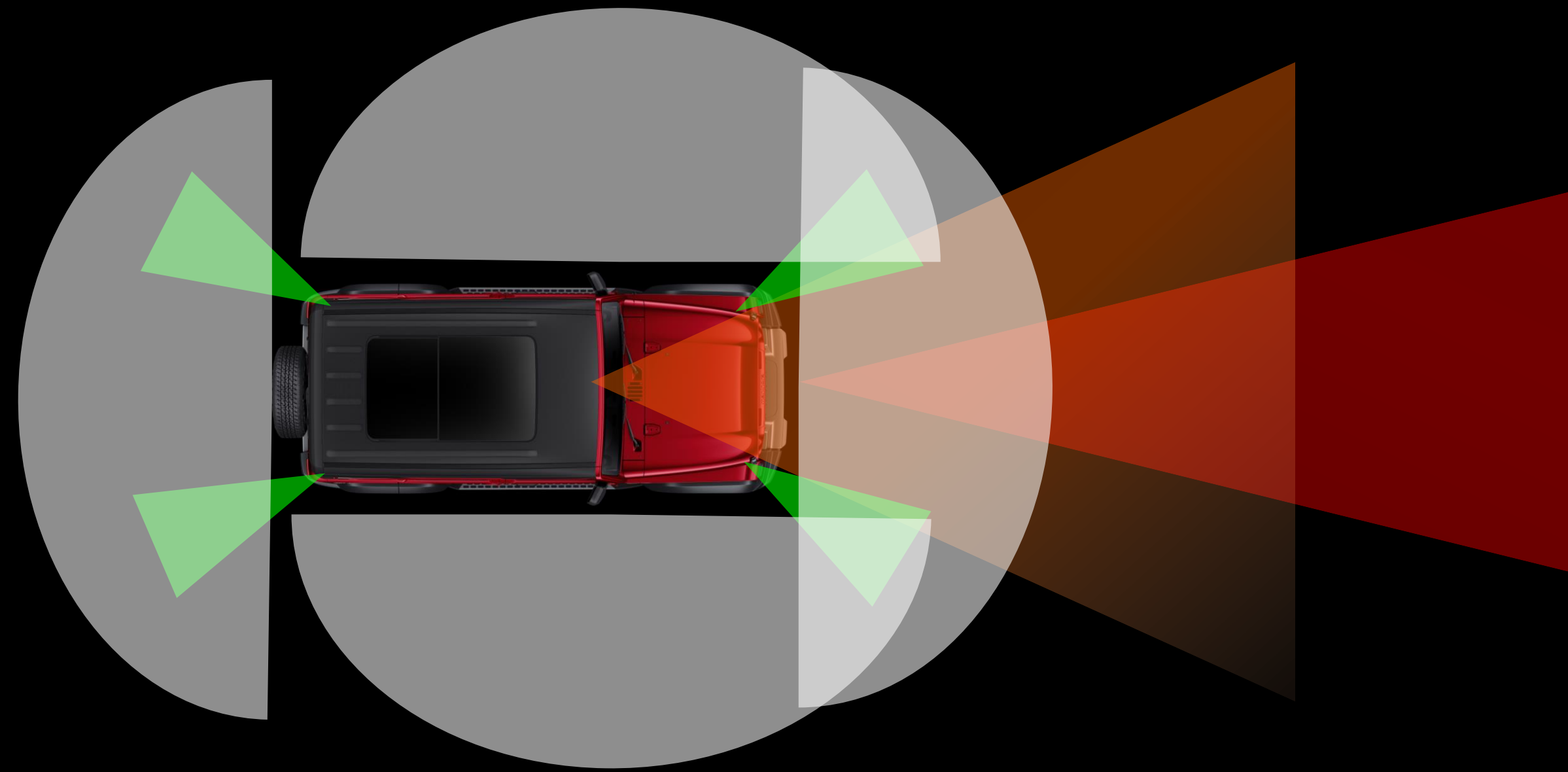

- Front RADAR
- Front Camera
- Surround Cameras
- Ultrasonic sensors

## Expansive list of features



- Forward collision warning (FCW)
- Auto Emergency Braking (AEB)
- Adaptive Cruise Control (ACC)
- Smart Pilot Assist (SPA)
- Lane Departure Warning (LDW)
- Lane Keep Assist (LKA)
- Traffic Sign Recognition (TSR)
- High Beam Assist (HBA)

# 'THE' SUV : Tough yet Sophisticated

Harman/Kardon Branded Audio



- 9 high-performance speakers
- 12-channel dedicated 560 W amplifier
- Clari-Fi (reveal beautiful and delicate audio details)
- Individual Audio Settings
  - Studio
  - QLS (Quantum Logic Surround)
  - Sound Ambience (Stage, Party, Retreat, Immersive)
- VNC+ (Vehicle Noise Compensation)
- 9-Band Equalizer

# 'THE' SUV : Tough yet Sophisticated

## Powered and Ventilated Seats

### Powered Seat : Driver

- 6-way adjustable power
- Ergonomic placement of knobs



### Ventilated Seats : Driver & Co-Driver

- Low-noise, high-flow fans
- Dedicated fans for cushion and backrest



# 'THE' SUV : Tough yet Sophisticated

## 360 deg Surround View System

### 360 deg Surround View

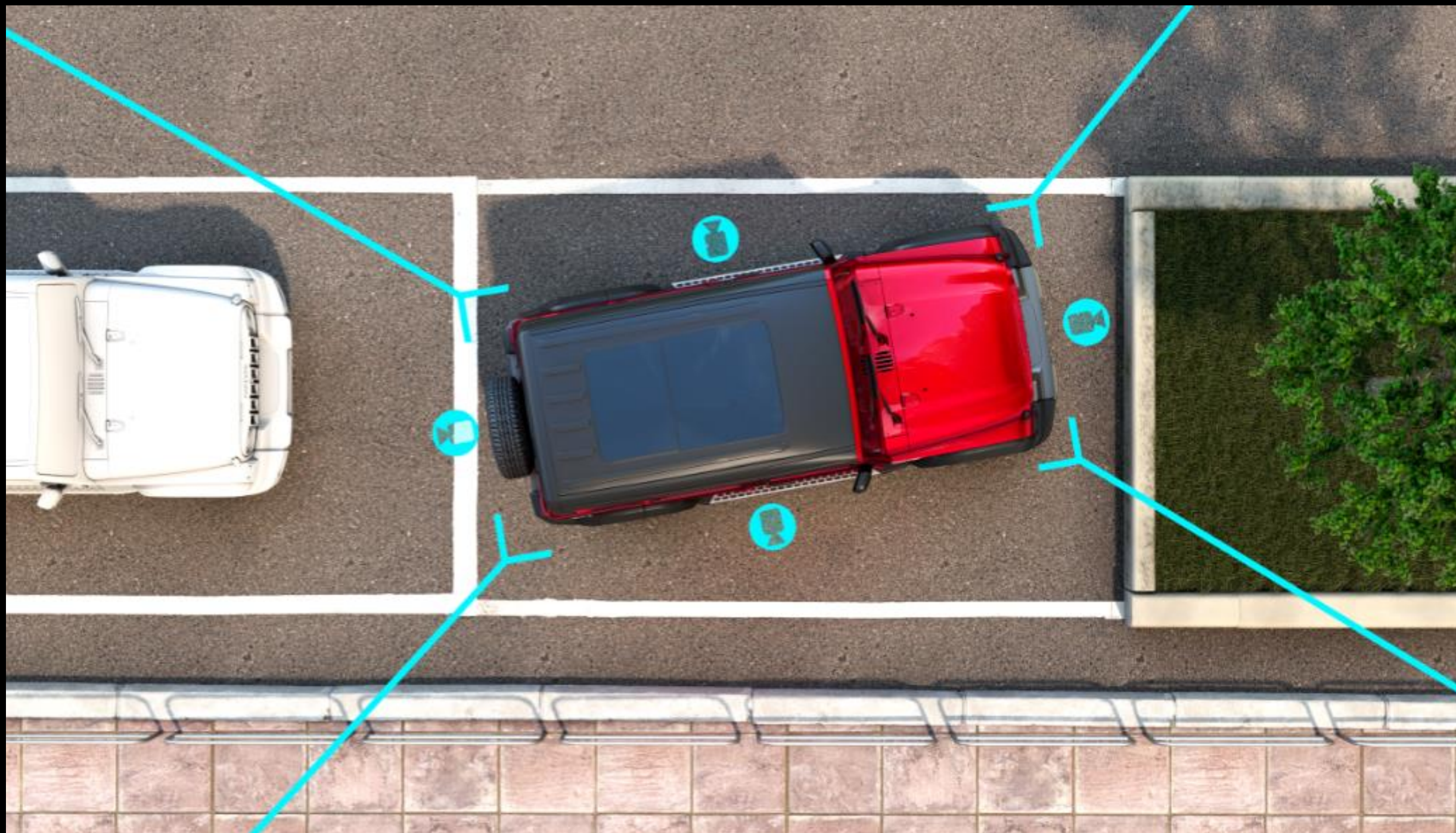

### Feature Packed SVS

- Blind View Monitor
- Front & Rear Parking Sensors
- Drive Video Recording
- Static & Dynamic Guidelines
- Intuitive animations.
- Interactive parking guidance
- Multiple View Options
  - 3D, Transparent, Wide, Full-screen

# 'THE' SUV : Tough yet Sophisticated

## ADRENOX Connect



**80+** 

### FEATURES

- Trip Summary
- Remote vehicle controls
- M-Lens
- Vehicle status monitoring
- Smart wearables
- In-home Alexa
- OTA Capable

# 'THE' SUV



**Panoramic Sunroof**



**Soft Touch IP**



**Concert on Wheels**



**10.25" dual touchscreen**



**Ventilated & Powered Seats**

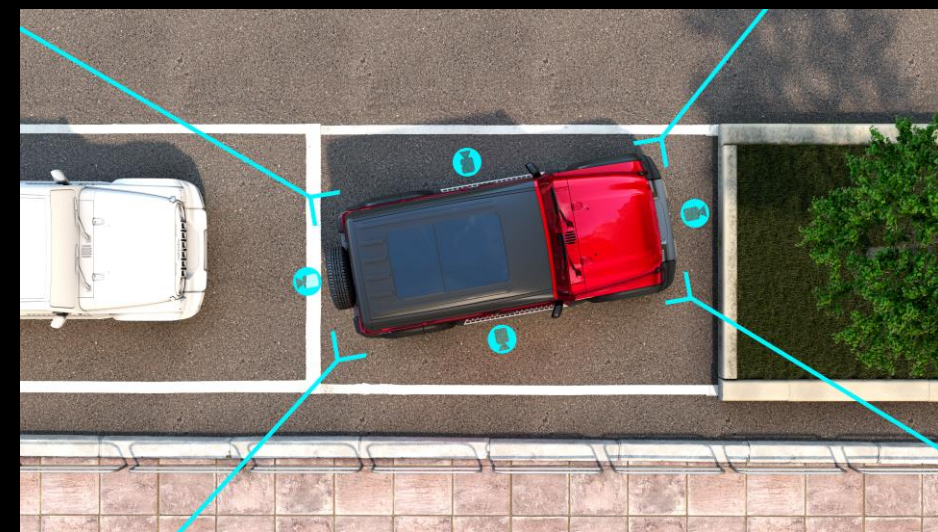

**360-degree camera with  
blind view monitoring**



**ADAS Level 2**



**80+ Connected features**









# THAR ROXX MX1: Base, But Not Basic!

**12.99 Lakh**  
**G MT RWD**

**13.99 Lakh**  
**D MT RWD**

## Turn Heads

Thar Iconic Silhouette  
LED Projector Headlamps  
LED Tail Lamps  
R18 Steel Wheels

## Don't Just Ride, Glide

M-Glyde Platform  
Penta Link Suspension with  
Watt's Link  
FDD (Frequency Dependent  
Damping)  
Electronic Power Steering

## Get Off the Tar

Brake Locking Differential  
Water wading - 650mm  
Approach angle - 41.3°  
Departure angle - 36.1°

## Power On

Power 119 kW; Torque : 330 NM  
(Gasoline MT)  
Electronic Stability Control (ESC)  
6 Airbags standard  
3 Point seatbelt for all passengers

## Rock the Luxe Life

Premium Embossed Fabric Upholstery  
Touchscreen Infotainment (26.03 cm)  
Push Button Start  
60:40 split rear seat  
Rear AC vents & USB-C Port



# THAR ROXX MX3: Level Up

**14.99 Lakh**  
**G AT RWD**

**15.99 Lakh**  
**D MT RWD**

## Turn Heads

### Dual-Tone Metal Top

Thar Iconic Silhouette  
LED Projector Headlamps  
LED Tail Lamps  
R18 Steel Wheels

## Don't Just Ride, Glide

### Drive Modes : Zip, Zoom

**Rear Armrest with cupholder**  
M\_GLYDE Platform

## Get Off the Tar

**Selectable Terrain Modes : Snow ,  
Sand, Mud**

**Gen II Adventure statistics**  
**Compass, Roll & Pitch, Altimeter**

## Power On

### Reverse Camera

**All 4 Disc Brakes (Petrol AT)**

**Hill Hold Control (HHC) & Hill Descent  
Control (HDC)**

**Traction Control System (TCS)**

## Rock the Luxe Life

### 26.03 cm HD Infotainment

**Wireless Android Auto & Wired Apple Car Play**

**Cruise Control**

**Auto Dimming IRVM**

**Wireless Charger**

**One Touch Power Window**

# THAR ROXX AX3L:

## Where Tech takes the wheel

**16.99 Lakh**  
**D MT RWD**

### Turn Heads

Thar Iconic Silhouette  
Dual-Tone Metal Top  
LED Projector Headlamps  
LED Tail Lamps  
R18 Steel Wheels

### Don't Just Ride, Glide

Drive Modes : Zip, Zoom  
Rear Armrest with cupholder  
M\_GLYDE Platform

### Get Off the Tar

Selectable Terrain Modes : Snow ,  
Sand, Mud  
Gen II Adventure statistics  
Compass, Roll & Pitch, Altimeter

### Power On

**Level 2 ADAS (10 Features)**  
**- Automatic Emergency Braking**  
**Electric Park Brake with Auto Hold**  
All 4 Disc Brakes (Petrol AT)  
Hill Hold Control (HHC) & Hill Descent  
Control (HDC)  
Traction Control System (TCS)

### Rock the Luxe Life

**26.03 cm HD Digital Cluster**  
**Adrenox Connect with built-in Alexa**  
**Wireless AACP**  
**Fully Automatic Temperature Control**  
**DTS Sound Staging**  
26.03 cm HD Infotainment  
Cruise Control  
Auto Dimming IRVM



# THAR ROXX **MX5**: Style meets Substance

**16.99 Lakh**  
**D MT RWD**

## Turn Heads

**Single Pane Sunroof**  
**R18 Diamond Cut Alloy Wheels**  
**C-Shaped LED DRL**  
**LED Front Fog Lamp**

## Power On

**4x4 variants**  
**Front Parking Sensors**  
**Reverse Camera**  
**All 4 Disc Brakes (Petrol AT)**  
**Hill Hold Control (HHC) & Hill Descent Control (HDC)**  
**Traction Control System (TCS)**

## Don't Just Ride, Glide

**Acoustic Windshield**  
**Leatherette Seats**  
**Leather Wrapped steering**  
**Drive Modes : Zip, Zoom**  
**M\_GLYDE Platform**

## Rock the Luxe Life

**Auto Head Lamp + Auto Wiper**  
**Footwell Lighting**  
**26.03 cm HD Infotainment**  
**Wireless Android Auto & Wired Apple Car Play**  
**Cruise Control**  
**Auto Dimming IRVM**

## Get Off the Tar

**Tyre Pressure Monitoring System**  
**Electronic locking differential (4x4)**  
**Selectable Terrain Modes : Snow , Sand, Mud**  
**Gen II Adventure statistics**





# THAR ROXX AX5L:

Living life, Fully loaded

**18.99 Lacs**  
**D AT RWD**

## Turn Heads

Single Pane Sunroof

R18 Diamond Cut Alloy  
Wheels

C-Shaped LED DRL

LED Front Fog Lamp

## Don't Just Ride, Glide

Acoustic Windshield

Leatherette Seats

Leather Wrapped steering

## Get Off the Tar

Tyre Pressure Monitoring System

Electronic locking differential (4x4)

## Power On

**Level 2 ADAS (10 Features)**

- **Automatic Emergency Braking**

Electric Park Brake with Auto Hold

Diesel 4x4 variants

Front Parking Sensors

## Rock the Luxe Life

**26.03 cm HD Infotainment**

**26.03 cm HD Digital Cluster**  
**Adrenox Connect with built-in Alexa**

**Wireless AACP**

**Fully Automatic Temperature Control**

**DTS Sound Staging**

Auto Head Lamp + Auto Wiper

Footwell Lighting



**ONE TO  
RULE  
THEM ALL**





# THAR ROXX AX7L: Luxury without Limits

**18.99 Lacs**  
**D MT RWD**

## Turn Heads

**Panoramic Skyroof (Largest under 4.5m)**

**R19 Diamond cut Alloy Wheels**

**C-Shaped LED DRL**

**LED Front Fog Lamp**

**Thar Iconic Silhouette**

## Don't Just Ride, Glide

**Leatherette Wrapped IP, door trims & steering**

**6 Way Powered driver seat**

**Front Ventilated Seats**

**Cooled Glove Box**

**Acoustic Windshield**

**Leatherette Seats**

## Get Off the Tar

**SmartCrawl (4x4)**

**Intelliturn (4x4)**

**Front Camera**

**Drive & Terrain modes**

**Gen II Adventure statistics**

**Break locking differential**

**Electronic locking differential (4WD)**

## Power On

**360 Surround view system with Blind view monitor**

**Obstacle view**

**Level 2 ADAS**

**Automatic Emergency Braking**

**Electric Park Brake with Auto Hold**

## Rock the Luxe Life

**9 Speaker Harman/Kardon branded audio with sub woofer**

**Power fold ORVM**

**65 Watt USB-C Charger**

**26.03 cm HD Infotainment 26.03 cm HD Digital Cluster Adrenox Connect with built-in Alexa**

**Wireless AACP**

**Fully Automatic Temperature Control**



# **THAR** **R O X X**

---

**Test Drives Start : Sept. 14<sup>th</sup>**

**Bookings Start : Oct. 3<sup>rd</sup>**

**Deliveries Start : This Dussehra**

# FREEDOM DRIVE PLAN

**THAR**  
**R O X X**



**THAR**  
**R O X X**

# FREEDOM DRIVE ROUTE

Hyatt to golf

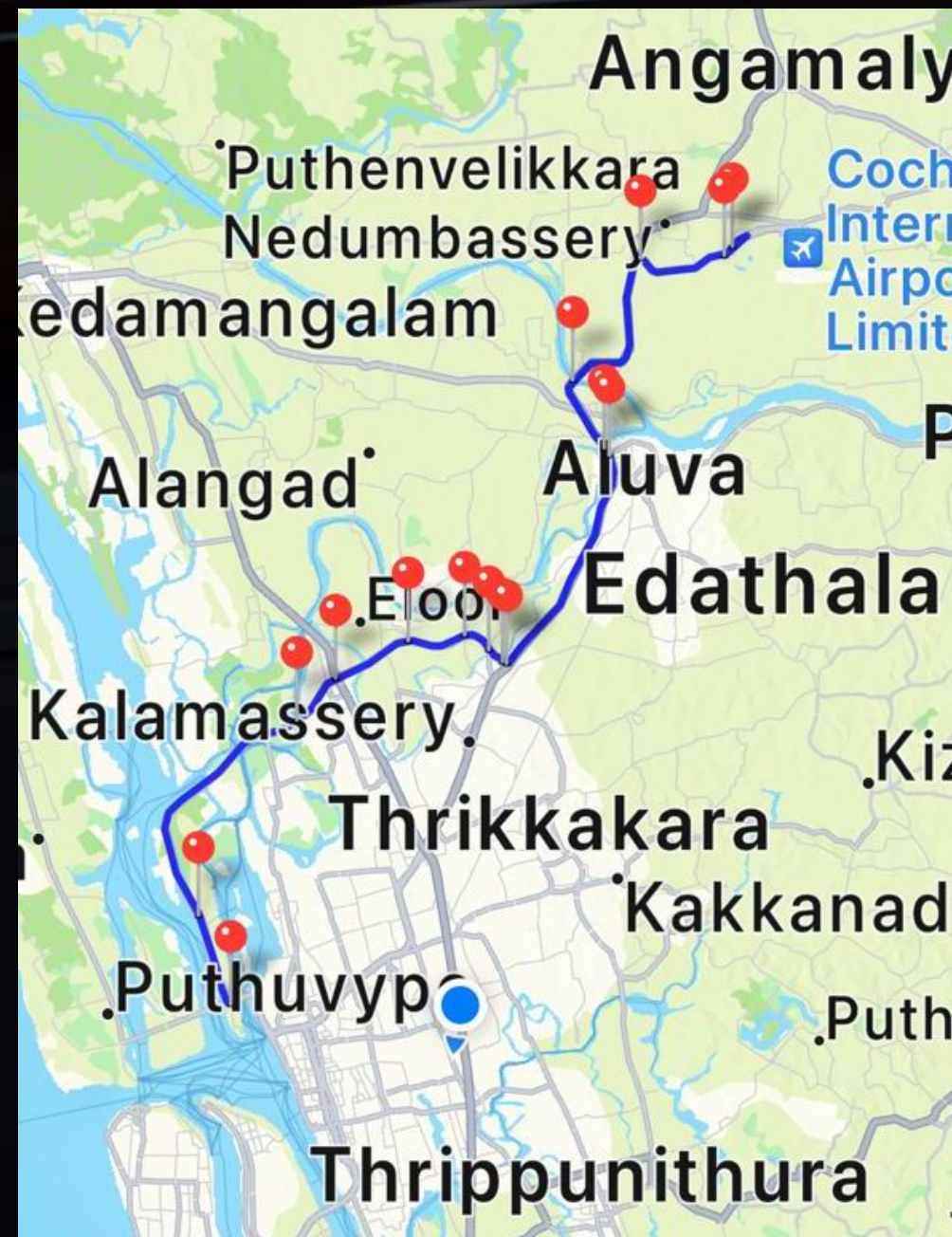

Golf to off road  
Demo track

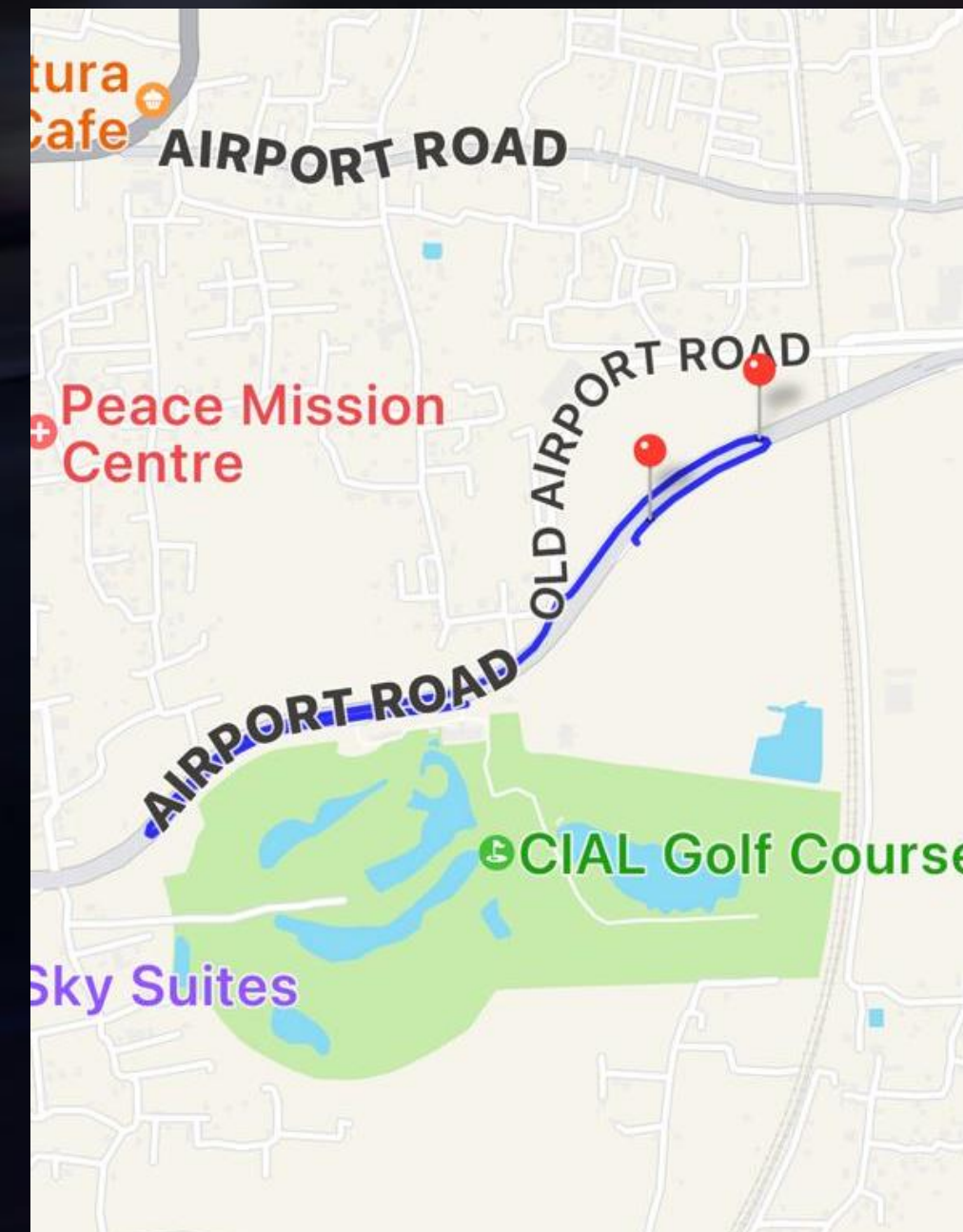

The plantation  
drive

